

BIG GULP Sapphire Scientific 3500

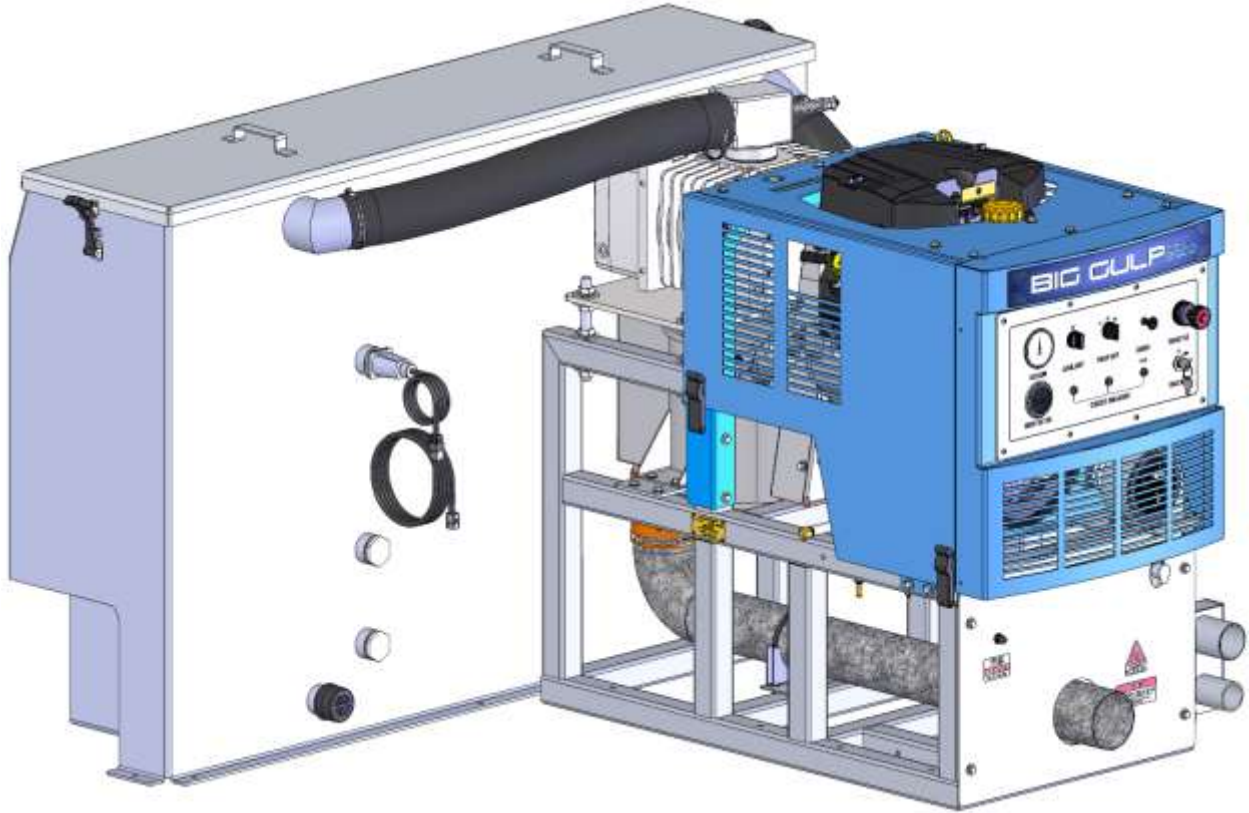

SERVICE AND OPERATION MANUAL



2604 Liberator, Prescott, AZ 86301

1-866-445-3030

Congratulations on your purchase of the **Big Gulp 3500** Portable Extraction Unit. This instruction and parts manual is a guide for operating and servicing your **Sapphire Scientific** equipment.

Proper operation and service are necessary to ensure the outstanding performance of this unit. When properly maintained, your unit will have a long and trouble-free life.

The following service methods outlined in this manual are detailed in a manner that operation and servicing may be performed properly and safely. Because service levels vary due to the skill of the mechanic, tools and parts availability, ensure that prior to attempting any maintenance or repair, you are familiar with the equipment and have all the proper tools to complete the task. Please call a **Sapphire Scientific** service representative at 1-800-445-3030 for help with maintenance, repair and warranty related questions.

The headings “**WARNING**” and “**CAUTION**” are utilized to warn you that steps must be taken to prevent personal injury or damage to the equipment. Please make sure that you have read and understand these instructions entirely before proceeding with the operation of this unit.

THIS UNIT MUST BE INSTALLED BY THE DEALER THAT YOU PURCHASED IT FROM IN ACCORDANCE WITH THE SAPPHIRE SCIENTIFIC INSTALLATION PROCEDURES.

This unit was manufactured by:

Sapphire Scientific
2604 Liberator
Prescott, AZ 86301
USA

 **WARNING!** Do not alter or modify your **Big Gulp 3500** in any way. Use only replacement parts authorized by **Sapphire Scientific**. Modifications or use of unapproved parts could create a hazard and will void your warranty. Contact a **Sapphire Scientific** service representative at 1-800-932-3030 for assistance.

Be sure to fill out the warranty card online at: <http://www.sapphirescientific.com>

This service and operations manual is written specifically for the **Big Gulp 3500** unit.

Published by **Sapphire Scientific**.
First Printing: September 2011
Printed in USA

Big Gulp 3500 MANUAL
SAPPHIRE SCIENTIFIC P/N 49-080
REVISION D, FEBRUARY 2016

The information contained in this document is subject to change without notice and does not represent a commitment on the part of **Sapphire Scientific**.

All rights reserved. Copyright 2016 by **Sapphire Scientific**. No part of this work may be used or reproduced in any form or means without the express written consent and permission of **Sapphire Scientific**.

SAPPHIRE SCIENTIFIC LIMITED WARRANTY

Sapphire Scientific Big Gulp 3500

What Does This Warranty Cover?

This warranty covers the Sapphire Scientific Model Big Gulp 3500 and is provided to the original purchaser only.

How Long Does This Warranty Last?

This warranty runs for:

Two (2) years from the date of installation on parts and labor (Excluding normal maintenance items.) Factory installed original belts are covered for 500 hours. Recovery tank and frame are covered for five years. All other components including seals, o-rings and electrical components are covered for the entire three year warranty period.

What Sapphire Scientific Will Do:

If a defect in materials or workmanship occurs within the warranty period, Sapphire Scientific at its election will repair or replace the defective part at no charge.

What This Warranty Does Not Cover:

This warranty does not cover or apply to defects due directly or indirectly to misuse, abuse, disassembly, alteration, corrosive chemicals, improper voltage, improper fuel, fire, flood, negligence, accident, improperly or incorrectly performed maintenance or repair, or failure to perform necessary or recommended maintenance or repair (See your Owner's Manual) or if the use of this product is not in compliance with the instructions and specifications for its use. This warranty does not cover normal maintenance items such as air and oil filters, lubricants and tune up parts. Paint is not covered. recovery tank and frame are covered for five years. All other components including seals, o-rings and electrical components are covered for the entire two year warranty period. We limit all implied warranties to:
Two (2) years from the installation date on parts and labor.

OTHER THAN THE WARRANTIES PROVIDED HEREIN, SAPPHIRE SCIENTIFIC MAKES NO EXPRESS OR IMPLIED, ORAL OR WRITTEN WARRANTIES WITH RESPECT TO THIS PRODUCT OR WORKMANSHIP AND ALL WARRANTIES IMPLIED BY LAW INCLUDING ANY WARRANTIES OF MERCHANTABILITY OR FITNESS FOR A PARTICULAR PURPOSE ARE LIMITED TO THE DURATION OF THIS WARRANTY. **Some states do not allow limitations on how long an implied warranty lasts, so the above limitations may not apply to you.** WE SHALL IN NO EVENT BE LIABLE FOR DEATH, INJURIES TO PERSONS OR PROPERTY OR FOR INCIDENTAL, CONTINGENT, SPECIAL OR CONSEQUENTIAL DAMAGES ARISING FROM USE OF OUR PRODUCTS. **Some states do not allow the exclusion or limitation of incidental or consequential damages, so the above limitation or exclusion may not apply to you.**

How Do I Get Service?

In order to be eligible for service under this warranty you MUST do the following: (a) fill out the warranty registration card on-line within thirty (30) days of the installation of our product; (b) write or call a service representative at Sapphire Scientific for a return material authorization (RMA); and (c) have the serial number available. Proof of proper maintenance may be required before warranty is granted.

Contact us at:

Sapphire Scientific
2604 Liberator, Prescott, AZ 86301
Phone: 928-445-3030 / 866-445-3030

If Sapphire Scientific uncovers a defect we will repair or replace the product, at our election. Ground shipping and transportation costs will be covered by the manufacturer. Returning defective parts to the manufacturer, if required, shall be the responsibility of the purchaser. Warranty may be denied if defective parts are not returned within the allotted 30 days. If it is determined that there is no defect in the product, or that the defect resulted from causes not within the scope of our warranty, then the product will be repaired or replaced only at your request and at your expense and you must bear all shipping costs.

How Does State Law Apply?

This warranty gives you specific legal rights, and you may also have other rights which vary from state to state.

TABLE OF CONTENTS

SECTION ONE: GENERAL INFORMATION	1
CONTACT INFORMATION	2
SAFETY - WARNINGS AND CAUTIONS.....	3
SPECIFICATIONS	8
INSTALLATION REQUIREMENTS	9
FUEL REQUIREMENTS.....	9
ENGINE OIL REQUIREMENTS.....	10
BATTERY CONNECTION	10
RECEIVING YOUR EXTRACTION SYSTEM	11
SECTION TWO: INSTALLATION	13
INSTALLATION	14
SECTION THREE: OPERATION	19
UNDERSTANDING THE SYSTEMS.....	20
OPERATION	23
FREEZE PROTECTION	29
SECTION FOUR: SERVICE AND MAINTENANCE	31
ROUTINE MAINTENANCE CHART	32
SERVICE CHART	33
MAINTENANCE	34
GENERAL SERVICE ADJUSTMENTS.....	39
TROUBLESHOOTING.....	40
SECTION FIVE: PARTS AND ACCESSORIES	43
ILLUSTRATED PARTS LISTING	44
ELECTRICAL DIAGRAMS	59
OPTIONAL EQUIPMENT	61
FUEL HOOK-UP KITS	63
FUEL LINES/PUMP INSTALLATION.....	67

SECTION ONE: GENERAL INFORMATION

CONTACT INFORMATION	2
WARNINGS AND CAUTIONS	3
SPECIFICATIONS	
TORQUE VALUES.....	8
REQUIREMENTS	
INSTALLATION REQUIREMENTS.....	9
FUEL REQUIREMENTS.....	9
ENGINE OIL REQUIREMENTS.....	10
BATTERY CONNECTION.....	10
RECEIVING YOUR EXTRACTION SYSTEM	
ACCEPTANCE OF SHIPMENT.....	11
EQUIPMENT LISTING.....	11
OPTIONAL EQUIPMENT.....	11
FUEL HOOK-UP KITS BY VEHICLE.....	12

CONTACT INFORMATION

For information about unit operation, maintenance or repair of your Sapphire Scientific equipment, please contact your local distributor.

To locate a local distributor, please visit our web site: <http://www.sapphirescientific.com/>

North American Distributors:

http://www.sapphirescientific.com/SSX_DistributorListings_NorthAmerica.aspx

If you need to contact Sapphire Scientific directly, for questions regarding this manual, service questions that cannot be resolved by your distributor, or other general information, please contact our service department here:

Phone: 1-800-932-3030

Service Email: service@sapphirescientific.com

Please fill in the information below so that you will have it on hand when contacting your distributor or Sapphire Scientific.

Serial Number:

Date of Purchase:

Purchased From (Distributor):

WARNINGS AND CAUTIONS

WARNING

Sapphire Scientific uses this WARNING symbol throughout the manual to warn of the possibility of physical injury or fatality. Please read all warnings carefully before operating the equipment.

CAUTION

Sapphire Scientific uses this CAUTION symbol throughout the manual to warn of the possibility of damage to equipment or personal property.

FOR YOUR SAFETY

The following warning labels are on your **Big Gulp 3500** console. These labels point out important **WARNINGS** and **CAUTIONS**, which must be followed at **ALL** times. Failure to follow these warnings could result in injury or fatality to yourself and/or others or property damage. Please follow these instructions carefully! **Do NOT remove these decals.**

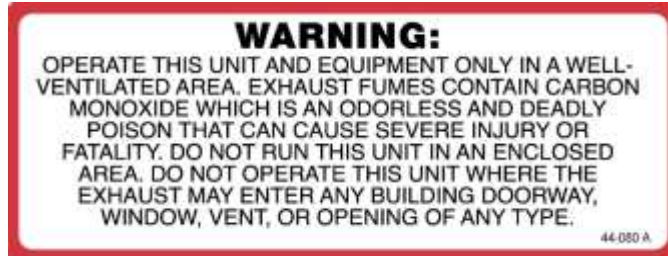

ROTATING MACHINERY. WATER UNDER PRESSURE AT HIGH TEMPERATURE. IMPROPER MODIFICATION OF EQUIPMENT CAN CAUSE SEVERE PERSONAL INJURY OR COULD BE FATAL.



 **WARNING**

1. **Read the operator's manual before starting this unit.**
Failure to adhere to instructions could result in severe personal injury or could be fatal.

 **WARNING**

2. **Operate your equipment in a well-ventilated area.**
Exhaust fumes contain carbon monoxide, which is an odorless and deadly poison that can cause severe injury or death. **DO NOT** run this equipment in an enclosed area. **DO NOT** operate this unit where the exhaust may enter a building doorway, window, vent or other opening.



 **WARNING**

3. **Gasoline is extremely flammable and its vapors can explode if ignited.** Store gasoline only in approved containers, in well-ventilated, unoccupied buildings and away from sparks or flames.

 **WARNING**

4. **DO NOT** operate unit if gasoline is spilled. Do not turn ignition switch until the gasoline has been cleaned up. Never use gasoline for cleaning purposes.

 **WARNING**

5. **DO NOT** place hands, feet, hair, clothing or any body parts near rotating or moving parts. Rotating machinery can cause severe injury or death.

 **WARNING**

6. **NEVER** operate this unit without belt and safety guards. High speed moving parts, such as belts and pulleys should be avoided while the unit is running. Severe injury, fatality and/or damage may result.

 **WARNING**

7. **NEVER** service a unit while it is running. High speed mechanical parts as well as high temperature components and fluids may result in severe injury or fatality.

 **WARNING**

8. Engine and vacuum pump components, hoses and fittings will be extremely hot from operation. To prevent severe burns, **DO NOT** touch these areas while the unit is running, or shortly after the unit is shut off.

 **WARNING**

9. **DO NOT** touch any part of the exhaust system while the system is running or for 20 minutes after the unit is shut off. Severe burns could result.

 **WARNING**

10. **Battery acid contains sulfuric acid.** To prevent acid burns, avoid contact with skin, eyes and clothing. Batteries also produce explosive hydrogen gases while charging. To prevent fire or explosion, charge batteries only in a well ventilated area. Keep sparks, open flames, as well as other sources of ignition away from battery at all times. Remove all jewelry prior to servicing batteries. Keep batteries out of the reach of children.

Before disconnecting the negative (-) ground cable, ensure that all switches are in the off position. If on, a spark could occur at the ground connection terminal which could cause an explosion if hydrogen gas or gasoline vapors are present. **ALWAYS** disconnect the negative (-) terminal first

 **WARNING**

11. **DO NOT** smoke around the equipment. Gas fumes could accumulate and ignite. Battery gasses are extremely flammable. This will prevent possible explosions.

 **WARNING**

12. **NEVER** cut or splice any of the equipment fuel lines. This will result in fuel leaks and potentially dangerous conditions. Use only the provided fuel hose for fuel lines.

 **WARNING**

13. The Occupational and Health Administration (OSHA) recommends the use of hearing protection when a technician is exposed to an average of 85 decibels (this is an average of exposure over an 8 hour period). This equipment can produce 85 decibels at a distance of 10 feet. Please check with your local state agencies to see if OSHA standards apply to your application.

 **WARNING**

14. California Proposition 65 Warning: Engine exhaust from this product contains chemicals known by the State of California to cause cancer, birth defects, or other reproductive harm.

SECTION ONE – GENERAL INFORMATION

CAUTION

1. Always keep your equipment clean and maintained. Proper performance relies heavily on regularly maintained hoses, tools, filters and strainer baskets.

CAUTION

2. Ensure that you have received proper training and are familiar with the start-up and shut-down procedures prior to operation.

CAUTION

3. **DO NOT** alter or modify your **Big Gulp 3500** in any way. Use only replacement parts authorized by **Sapphire Scientific**. Modifications or use of unapproved parts could create a hazard and will void your warranty. This includes the use of any open ended hoses.

CAUTION

4. **Do NOT** run the waste pump dry (if installed). Doing so will damage the pump impeller.

SPECIFICATIONS

Engine Speed	2900 RPM (High Speed/No Load) 1500 RPM (Idle / No Load)
Vacuum Pump RPM	3265 RPM @ 2900 Engine RPM
Vacuum Relief Valve	13 in. Hg
Waste Pump RPM (if installed)	1305 RPM @ 2900 Engine RPM
Waste Pump GPM (if installed)	44 GPM @ 2900 Engine RPM
Recovery Tank Capacity at Shut-Off	100 gallons
Recovery Tank Gross Capacity	120 gallons
Console only weight	690 lbs. (optional waste pump not included)
Console/Tank (with hoses)	978 lbs. (optional waste pump not included)
Console/Tank Weight (full recovery tank)	1813 lbs. (optional waste pump not included)

TORQUE VALUES

Engine Hub Rear	13.3 ft./lbs. (160 in./lbs.)
Engine Hub Front	15 ft./lbs. (180 in./lbs.)
Vacuum Pump Hub	15 ft./lbs. (180 in./lbs.)

INSTALLATION REQUIREMENTS

Prior to beginning the installation, read the **ENTIRE Installation** section of this manual. Since the **SAPPHIRE SCIENTIFIC Big Gulp 3500®** extraction unit weighs approximately 978 lbs., please adhere to the following recommendations prior to installing the unit.



1. **DO NOT** exceed the vehicle's payload capacity. This will prevent unsafe or hazardous driving conditions. Before installing any components into the vehicle, check with the vehicle manufacturer for the Gross Vehicle Weight Rating (GVWR). GVWR is the maximum allowable combined weight of the vehicle, including all passengers, fuel, fluids, tools and cargo.

Example: If the GVWR for a vehicle is 9600 lbs. and the vehicle has a base curb weight of 6406 lbs., this leaves a payload capacity of 3194 lbs. (GVWR - Curb Weight = Payload Capacity).

2. If mounting the unit in a trailer, ensure that the trailer is rated for the total weight of the unit and trailer. Electric or hydraulic brakes must be provided, and strict compliance with all State and Federal laws must be maintained.

3. SAPPHIRE SCIENTIFIC recommends using only a dual axle trailer. If mounting in a trailer, the SAPPHIRE SCIENTIFIC Big Gulp 3500 console must be positioned so that it balances properly with respect to the trailer axles. Ten percent (10%) of the unit's total overall weight (w/o accessories or water) should be on the tongue.

4. Adequate ventilation with either two sets of doors or a roof ventilation system is highly recommended.

5. Tires must have a load rating in excess of the combined unit and vehicle/trailer weight.

6. SAPPHIRE SCIENTIFIC does not recommend using any type of flooring materials that absorb water. This condition will result in rust and corrosion of the vehicle floor.

7. Insulation under rubber mats should be removed prior to installation of the unit.

FUEL REQUIREMENTS

Use unleaded fuel ONLY. Use only fresh, clean unleaded gasoline with a minimum octane rating of 87. **Do Not** use high octane gasoline. Gasoline with up to, not exceeding, 10% ethanol is acceptable.

Gasoline older than 30 days must be discarded and replaced with fresh gasoline.

NOTE: Using other gasoline/alcohol blends including E20 and E85 will cause damage to engine components and will void the warranty.

ENGINE OIL REQUIREMENTS

Use high-quality oil of at least API (American Petroleum Institute) service class SG, SH, SJ or higher. **Do not use additives.** A 20W-50 synthetic blend may be used after 50 hours of operation for a new or rebuilt engine to allow the piston rings to properly seat. It is never recommended to extend oil change intervals past 100 hours.

Engine oil capacity	2.8 L 2.9 U.S. qts
---------------------	-----------------------

Tightening torque	Drain	32.4 – 37.3 N·m
	Plug	3.3 – 3.8 kgf·m
		23.9 – 27.5 lbf·ft

BATTERY CONNECTION



WARNING

Explosive gases, Dangerous gases!

Batteries contain sulfuric acid. To prevent acid burns, avoid contact with skin, eyes and clothing. Batteries also produce explosive hydrogen gases while charging. To prevent fire or explosion, charge batteries only in a well ventilated area. Keep sparks, open flames, as well as any other sources of ignition away from batteries at all times. Remove all jewelry prior to servicing batteries. Keep batteries out of the reach of children.

Before disconnecting the negative (-) ground cable, ensure that all switches are in the OFF position. If ON, a spark could occur at the ground connection terminal, which could cause an explosion if hydrogen gas or gasoline vapors are present. ALWAYS disconnect the negative (-) terminal first.

- A. Attach the red positive (+) battery cable from the starter solenoid on the console to the positive (+) terminal on the battery and tighten down the nut.
- B. Attach the black negative (-) battery cable from the ground on the console to the negative (-) terminal on the battery and tighten down the nut

RECEIVING YOUR EXTRACTION SYSTEM

DEALER RESPONSIBILITY

THE DEALER THAT YOU PURCHASED THIS EXTRACTION SYSTEM FROM IS RESPONSIBLE FOR THE PROPER INSTALLATION OF THIS MACHINE.

THE DEALER IS ALSO RESPONSIBLE FOR THE PROPER INITIAL TRAINING OF YOUR OPERATORS AND MAINTENANCE PERSONNEL.

ACCEPTANCE OF SHIPMENT

This Big Gulp 3500 system was thoroughly tested, checked and inspected in its entirety prior to leaving our manufacturing facility. When receiving your unit, please make the following acceptance check:

1. The unit should not show any signs of damage. If there is damage, notify the deliverer immediately.
2. Carefully check your equipment. The Big Gulp 3500 system should arrive with the following items as well as any additional optional accessories you may have ordered:

EQUIPMENT LISTING

- Big Gulp 3500 or 3501 (3501 includes the automatic waste pump) Console
- Big Gulp 3500 Recovery Tank
- Operation and Service Manual
- Installation hardware and mounting plates
- Hoses and clamps for console to recovery tank connection and manual drain
- Fuel Pump and Filter
- Group 24 Battery Holder
- Recovery tank Air Filter
- Stainless Steel Strainer Basket
- 100 ft. of 2 in. Vacuum Hose

OPTIONAL EQUIPMENT (contact Sapphire Scientific to order separately)

DESCRIPTION	PART NUMBER
50 ft. 2 in. Vacuum Hose	18-003
50 ft. 2-1/2 in. Vacuum Hose	18-333
Hose connector	21-003
Rover HVE	

FUEL HOOK-UP KITS BY VEHICLE

- Chevy 1997 to 2002 FI..... 69-003FI
- Chevy 2003 FI..... 69-018FI
- Chevy 2004+ Hook-Up Kit 69-033
- Chevy Box Truck 2004+ 69-081
- Dodge 1997 to 2002 FI..... 69-004FI
- Ford FI 69-005FI
- Ford 2004 – 2010 69-061
- Ford 2011+ 69-331
- Ford Box Truck 2004+ 68-077
- Ford Transit Connect..... 69-261S
- Nissan NV 69-376

SECTION TWO: INSTALLATION

INSTALLATION

LIFTING THE UNIT INTO THE VEHICLE	14
POSITIONING THE UNIT INTO THE VEHICLE.....	14
FASTENING DOWN THE UNIT AND RECOVERY TANK	15
DIMENSIONAL DIAGRAMS	16
INSTALLATION OF FUEL LINES.....	17
TRAILER FUEL TANK AND FUEL LINE INSTALLATION	17
BATTERY CONNECTION	18
FIRE EXTINGUISHER.....	18

INSTALLATION



This unit must be bolted to the floor of the vehicle by an AUTHORIZED DISTRIBUTOR.

LIFTING THE UNIT INTO THE VEHICLE

The **Big Gulp 3500** console weighs approximately 690 lbs., a forklift is necessary to place the unit into the vehicle. Make **CERTAIN** that the forks are spread to the maximum width of the unit. Use C clamps to secure the unit to the forks.

POSITIONING THE UNIT INTO THE VEHICLE

Vehicles vary in size and openings. Owners have different preferences on where in the vehicle they want their units positioned. **Sapphire Scientific** strongly recommends a side door installation for the **Big Gulp 3500**. We **DO NOT** recommend a rear door installation.

1. Ensure that enough space is provided to assure adequate engine ventilation as well as room for service and maintenance.
2. The operating weight of the complete installation (which includes water weight) with recovery tank and all accessories **MUST NOT** exceed the vehicle's axle weight limit.
3. **NEVER** position the console closer than 12 inches from the bottom rear of the driver and passenger seats.

FASTENING DOWN THE UNIT AND RECOVERY TANK



Prior to drilling any holes in the vehicle floor, ensure that while drilling, you will not damage the fuel tank, fuel lines, or any other vital components, which could affect the safety and or operation of the vehicle.

1. The console and recovery tank mounting holes will serve as a template. Drill eight (8) $1\frac{13}{32}$ in. diameter holes for the console and seven (7) $1\frac{13}{32}$ in. diameter holes for the recovery tank.
2. Using the provided mounting hardware kit:
 - a. Insert grade 5, 3/8-16 × 4 in. hex head cap screws with flat washers through the console mounting holes, and grade 5, 3/8-16 × 4 in. hex head cap screws with flat washers through the recovery tank mounting holes.
 - b. Install the provided mounting plates underneath the vehicle floor.
 - c. Screw the provided 3/8-16 hex head lock nuts on to the mounting bolts and tighten until the console and recovery tank are firmly attached to the vehicle floor.

OVERALL DIMENSIONS

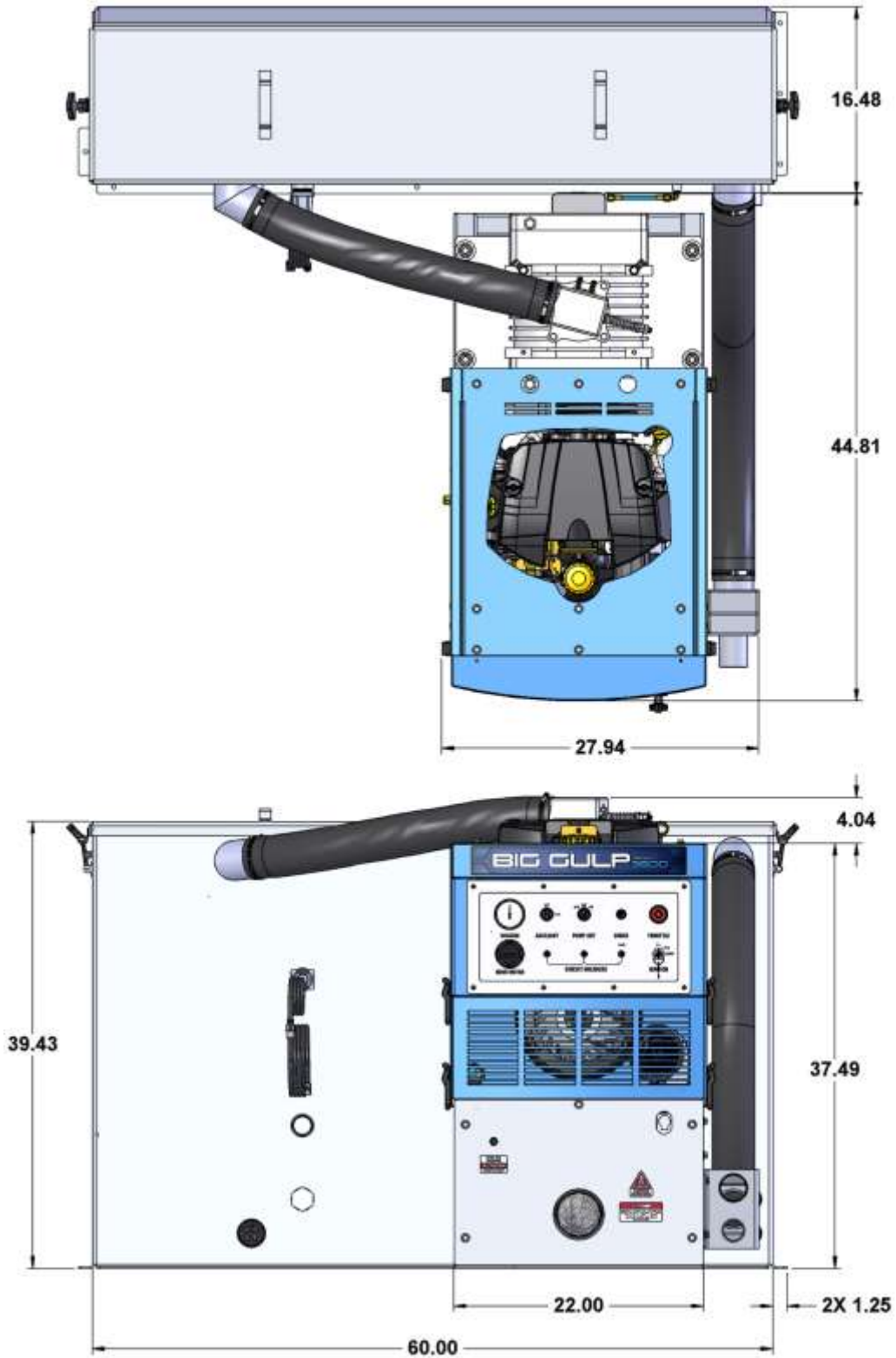

INSTALLATION OF FUEL LINES



CAUTION!!!

READ THESE INSTRUCTIONS ENTIRELY BEFORE PROCEEDING.



WARNING!

The Vehicle fuel lines should NOT be spliced under ANY circumstances. Severe injury or fatality could result.

DO NOT damage the vehicle in any way during the installation. When routing fuel lines, **DO NOT** configure the hoses in any location where the hoses or vehicle could be damaged. Avoid contact with moving parts, areas of high temperature, brake lines, fuel lines, catalytic converters, exhaust pipes, mufflers or sharp objects. Excess heat from exhaust or other heat sources may cause the fuel pump to work improperly.

TRAILER FUEL TANK AND FUEL LINE INSTALLATION

The following are recommendations for trailer installations:

- A. Strict compliance with all federal and state laws must be maintained.
- B. Use only fuel tanks that are manufactured specifically for gasoline, have proper vented filling caps, and outlet connections that are the same size as the inlet and return connections on the unit.
- C. **DO NOT** install fuel tanks inside any type of enclosed trailer or vehicle.



WARNING!

NEVER carry gasoline or flammable materials in an enclosed trailer or vehicle.

NEVER store any type of flammable material in an enclosed trailer or vehicle.

- D. Always mount fuel tanks where they will be protected from any vehicle collision.
- E. When installing fuel lines from the fuel tank to the unit, use the proper size fuel line.

BATTERY CONNECTION



EXPLOSIVE GASES, DANGEROUS GASES!

Batteries contain sulfuric acid. To prevent acid burns, avoid contact with skin, eyes and clothing. Batteries also produce explosive hydrogen gases while charging. To prevent fire or explosion, charge batteries only in a well ventilated area. Keep sparks, open flames, as well as any other sources of ignition away from batteries at all times. Remove all jewelry prior to servicing batteries. Keep batteries out of the reach of children.

Before disconnecting the negative (-) ground cable, ensure that all switches are in the OFF position. If ON, a spark could occur at the ground connection terminal, which could cause an explosion if hydrogen gas or gasoline vapors are present. ALWAYS disconnect the negative (-) terminal first.

- A. Attach the red positive (+) battery cable from the starter solenoid on the console to the positive (+) terminal on the battery and tighten down the nut.
- B. Attach the black negative (-) battery cable from the ground on the console to the negative (-) terminal on the battery and tighten down the nut.

FIRE EXTINGUISHER

Sapphire Scientific, and many government agencies, recommend that a fire extinguisher rated for A, B, and C type fires be installed into any commercial vehicle.

SECTION THREE: OPERATION

UNDERSTANDING THE SYSTEMS

VACUUM SYSTEM	20
WASTE PUMP SYSTEM (IF INSTALLED).....	22

OPERATION

PREPARATION	23
CONSOLE FUNCTIONS AND GAUGES	24
STARTING THE UNIT	26
AUTOMATIC WASTE PUMP (IF INSTALLED)	26
EXTRACTION PROCESS	26
SHUT-DOWN AND DAILY MAINTANENCE	27
AUTOMATIC SHUT DOWNS.....	28

FREEZE PROTECTION

WINTERIZING YOUR UNIT	29
-----------------------------	----

UNDERSTANDING THE SYSTEMS

NOTE: Read and understand this section of the manual entirely before operating the unit.

Prior to proceeding into the operations and maintenance sections of this manual it is recommended that you acquire a basic understanding of how the unit functions.

VACUUM SYSTEM

The flow of vacuum is initiated by the vacuum pump, which draws air through the recovery tank. A mixture of air and water is drawn into the recovery tank through a vacuum inlet near the front of the machine. The air and water continue to the recovery tank to a strainer basket. Here in the recovery tank, water and air separate. Water is deposited into the recovery tank while the air exits through a 100 mesh filtration system, into the vacuum pump. A relief valve is installed for vacuum pump protection.

The air is discharged from the vacuum pump through a spiral silencer, then exiting through the exhaust pipe on the front of the unit.

A high level shut off sensor is located on the front of the recovery tank and will shut down the unit before the tank is at full capacity. This protects the vacuum pump from water damage.

Note: Recovery tank high level shut off will not shut the unit off due to high levels of foam.

CAUTION

Do not alter the vacuum speed outside the recommended range shown in this manual. Doing so can result in severe damage to the unit and voidance of warranty.

CAUTION

Recovery tank level shut-off will not detect high foam levels. Foam entering the vacuum pump can cause damage to the unit. The use of a quality defoamer is recommended.

When the tank is full the unit will shut down and the waste water needs to be disposed of before the operation can continue.

IN ACCORDANCE WITH EPA, STATE AND LOCAL LAWS, DO NOT DISPOSE OF WASTE WATER INTO GUTTERS, STORM DRAINS, STREAMS, RESERVOIRS OR ANY NON-COMPLIANT RECEPTICLE.

Always check local laws and regulations regarding “gray” water disposal. The penalties for non-compliance can be serious.

VACUUM SYSTEM DIAGRAM

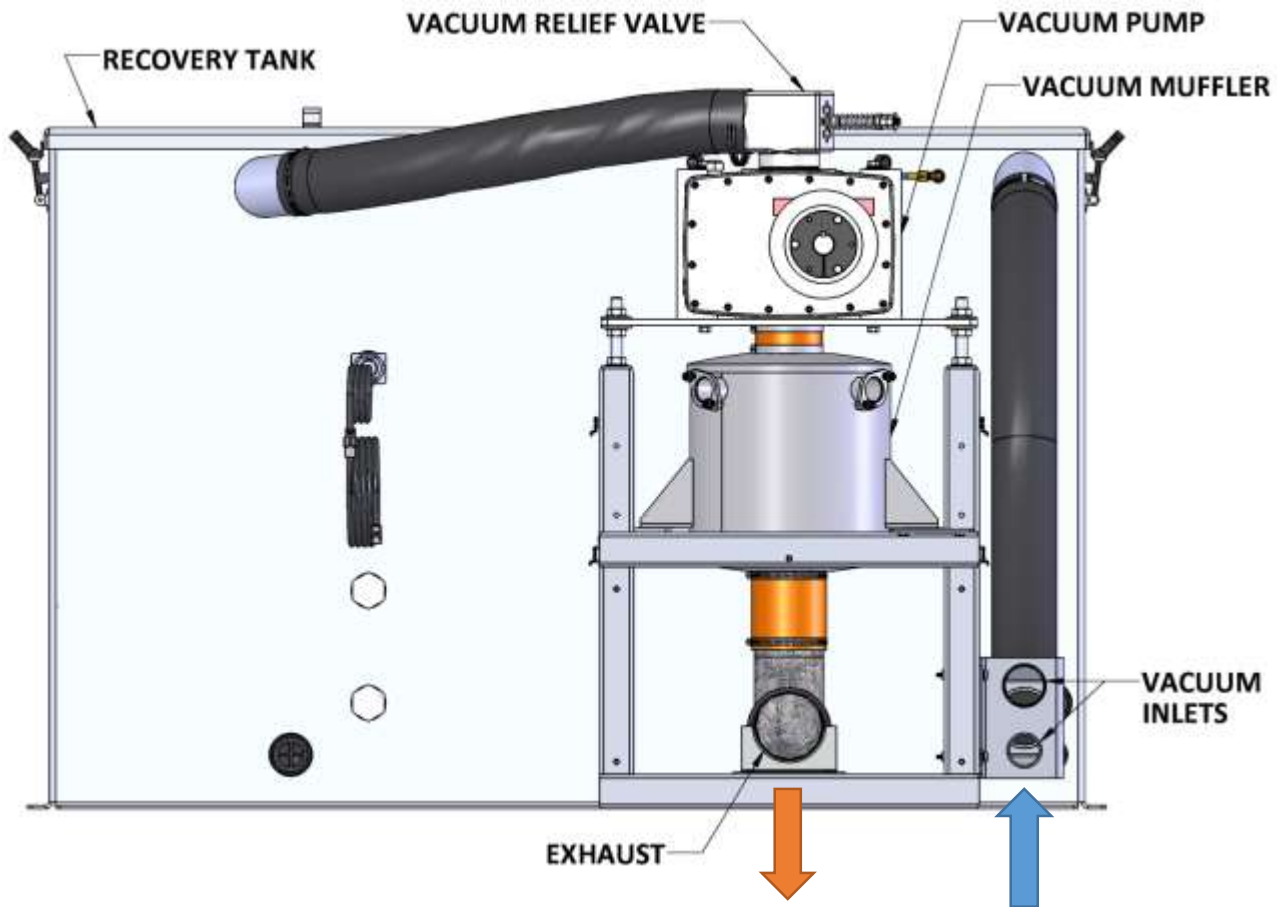

WASTE PUMP SYSTEM (IF INSTALLED)

The Big Gulp 3500 has the option to equip an automatic waste pump-out system which removes water from the recovery tank so that the unit can continue to extract larger volumes of water than the recovery tank can hold.

When turned on, the waste pump is automatically activated by a water level sensor in the recovery tank. This sensor prevents the pump from running dry and only activates the pump when there is enough water in the recovery tank to begin the removal process. Water is pumped from the supply port on the recovery tank, through the pump and out the outlet fitting.

A shut-off valve is connected to the pump to prevent leaking when not in use. Never run the pump with the valve in the off position. Running the pump dry will cause severe damage to the pump.

The recovery tank is also supplied with a manual drain port. The manual drain port must be used to drain remaining water and debris from the bottom of the recovery tank between jobs and during periods of storage.

In the case of a shut-down, the recovery tank must be manually drained below the shut-off level before the unit can resume operation.

CAUTION

Running the pump dry for any length of time will cause damage to the pump impellers and void your warranty.

WASTE PUMP SYSTEM DIAGRAM

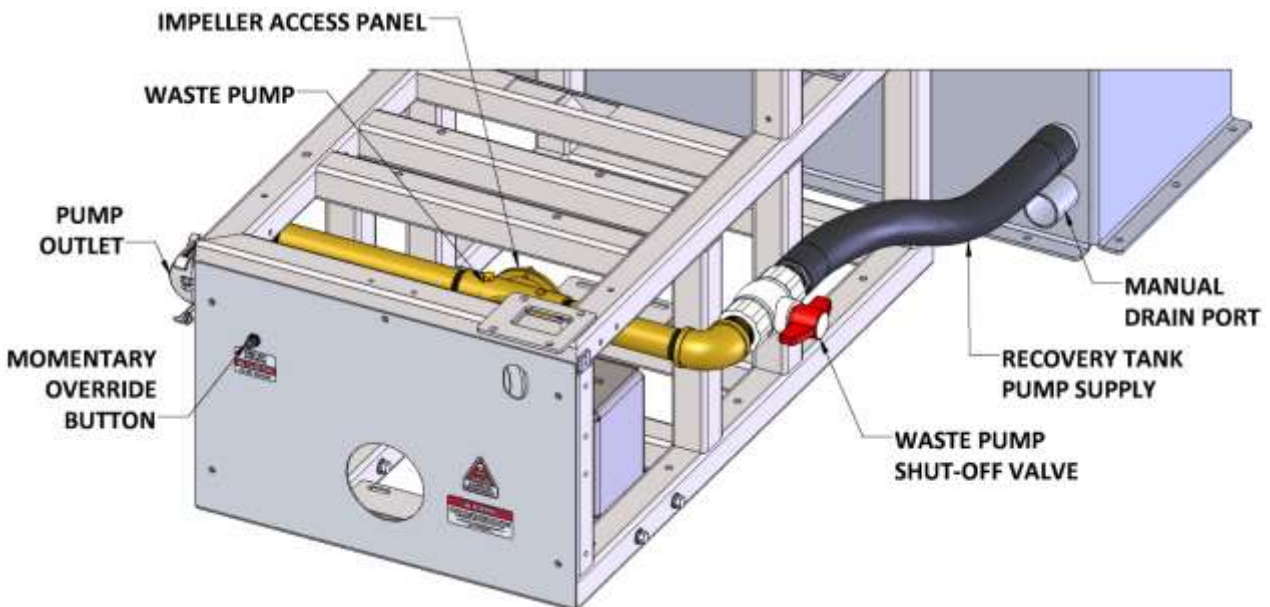

OPERATION

This section of the operator's manual explains how to prepare, start, operate, shut down and maintain your **Big Gulp 3500** direct-drive cleaning unit. The **Big Gulp 3500** unit is easy to operate, however only trained operators should proceed.

 **WARNING** Operate this unit and equipment only in a well-ventilated area. Exhaust fumes contain carbon monoxide, which is an odorless and deadly poison that can cause severe injury or death. DO NOT run this unit in an enclosed area. DO NOT operate this unit where the exhaust may enter a building doorway, window, vent or any other opening.

PREPARATION

ENSURE THERE IS ADEQUATE FUEL

Check the vehicle fuel level to ensure there is adequate fuel to complete the job and transport the vehicle.

 **CAUTION**
Do not operate machine with covers or guards removed.

CHECK YOUR DRAIN VALVES

Make sure the recovery tank drain is closed.

CHECK FILTERS

Inspect the vacuum inlet filter and strainer basket in the recovery tank. Inspect the strainer basket inside the pre-filter box. See the Shut Down and Daily Maintenance section below for more information.

 **CAUTION**
NEVER operate the unit with the recovery tank air filter removed, damaged or not properly installed.

CONSOLE FUNCTIONS AND GAUGES

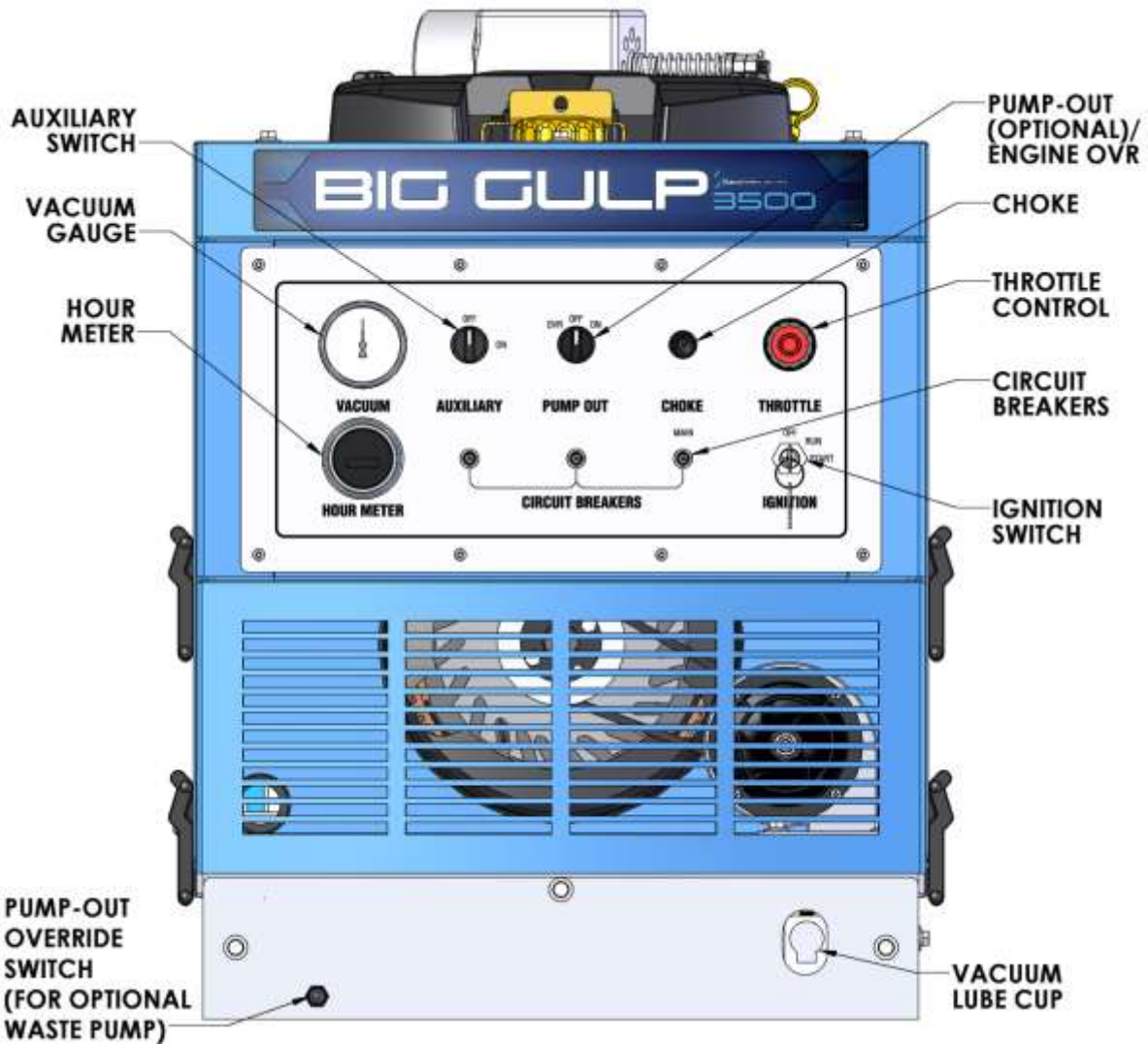

VACUUM GAUGE

With the unit running, the vacuum gauge should read near zero with vacuum hoses disconnected. If the gauge shows a reading, check the filter and the strainer basket in the recovery tank for debris. With vacuum ports sealed, and machine running at high speed, the vacuum gauge should read 11 to 13 inches of mercury (in. Hg). This is preset for the maximum safe operation.



DO NOT exceed 13 in. Hg vacuum pressure. This can cause damage to the vacuum pump.

SECTION THREE – OPERATION

AUXILLIARY SWITCH

The auxiliary switch is in place to control an auxiliary accessory item, if added, such as a motorized hose reel. Settings are ON or OFF.

PUMP OUT SWITCH / ENGINE OVERRIDE (ON/OFF/OVR)

The pump out switch is used to turn the pump ON or OFF (if installed). The OVR (Engine Override) setting is only used temporarily when starting the engine.

CHOKE CONTROL

The engine choke control knob. Pull to open the choke for engine ignition.

THROTTLE CONTROL

The engine throttle control knob. Turn counter-clockwise to open the throttle (faster speed), clockwise to close the throttle (slower speed). For emergency slow-down, depress the center button and push the throttle control in.

HOUR METER

The hour meter records the operating time of the machine. This information is used to calculate maintenance and service intervals. See the Service And Maintenance section in this manual for more information.

CIRCUIT BREAKERS

Main and auxiliary circuit breakers.

IGNITION SWITCH

The engine ignition switch provides ignition to start the engine when the key is inserted and turned. The Pump Out switch must also be held in the OVR position when starting the engine.

PUMP OUT OVERRIDE (LOWER PANEL – FOR OPTIONAL WASTE PUMP ONLY)

The pump out override button is used to assist in winterizing the pump with antifreeze. It can also be used, if needed, to remove standing water in the pump and/or hoses but only for a few seconds at a time. This is only used when an optional automatic waste pump has been installed.



Running the pump dry for any length of time will cause damage to the pump impellers and void your warranty.

VAC LUBE

The vacuum relief valve lubrication port is used to deliver lubrication to the vacuum pump. This prevents rust from building up inside the pump. See the shut-down and daily maintenance sections for more information.

STARTING THE UNIT

STARTING THE ENGINE

1. Set the **THROTTLE** control in, pull out engine **CHOKE**.
2. Hold the Pump Out switch in the **OVR** position while turning the ignition key to start the engine.
3. Once the engine is running, push in the engine **CHOKE**.
4. Set the **THROTTLE** to the desired speed.

NOTE: Do not operate the unit with the throttle set below 50% of maximum throttle setting.

CONNECT THE VACUUM HOSE

Connect the vacuum hose to the vacuum inlet connection at the front of the console. Make sure that any ports you are not using are capped.

ONBOARD AUTOMATIC WASTE PUMP (IF INSTALLED)

If you have an onboard automatic waste pump:

1. Connect your waste hose to the pump-out connection and the other end to an acceptable waste disposal.
2. Turn the pump-out switch located on the front console control panel to the **ON** position. The waste pump will now operate automatically throughout the cleaning period.



Running the pump dry for any length of time will cause damage to the pump impellers and void your warranty.



NEVER dispose of waste water in a storm drain, water way or on ground areas. Always dispose of waste in accordance with Local, State and Federal laws.

EXTRACTION PROCESS

After you have completed the previous steps, proceed with the extraction process. Place the throttle control lever to the desired speed for extraction. A float shut-off switch is located inside of the recovery tank. It will automatically shut down the unit if the tank reaches its full capacity. If this occurs, empty the recovery tank before continuing.

SHUT DOWN AND DAILY MAINTENANCE

1. Remove as much moisture from the vacuum hoses as possible. This will prevent spilling of waste water when recoiling the hoses.
2. Disconnect the vacuum hoses from the unit, leaving the vacuum port(s) open.
3. Make sure the PUMP OUT switch is in the OFF position after use (if a waste pump is installed).
4. Push the throttle control knob in to run at idle.
5. Allow the unit to run for 2 to 3 minutes. This will help to remove any excess moisture from the vacuum pump.

NOTE: If shutting down for the day – plug the vacuum inlet(s) and set the throttle to 50% of maximum throttle. Spray a water displacement/lubricant (i.e. WD-40) into the vacuum lubrication cup located on the lower front panel for 10 seconds. Run the unit for 1 to 2 minutes to lubricate the vacuum pump. Unplug the vacuum inlet and return the throttle control knob to run at idle.

6. Turn the ignition switch to the OFF position to shut down the engine.
7. Make sure the recovery tank is completely drained manually into an approved source.

WARNING

NEVER dispose of waste water in a storm drain, water way or on ground areas. Always dispose of waste in accordance with Local, State, and Federal laws.

8. Remove the recovery tank strainer basket and clean thoroughly before replacing.
9. Check the recovery tank filter for debris.

NOTE: To remove the vacuum inlet filter, grip the plastic hexagon section of the filter. Gripping the filter by the screen will collapse or destroy the filter. After cleaning, grease the threads on the filter and replace the filter. Tighten the filter until hand tight and then loosen ¼ turn. This will make the filter easier to remove when cleaning or replacement is required.

CAUTION

NEVER operate this unit with the filter removed, damaged or improperly installed.

At the end of the work day, rinse out the recovery tank with fresh water.

Clean the unit, tools, hoses etc., as needed. Inspect **ALL** equipment and accessories for any damage, leaks, wear, etc.

AUTOMATIC SHUT DOWNS

When the recovery tank is full, the engine will shut down. If this happens, make sure the PUMP OUT switch is in the OFF position (if an optional automatic waste pump is installed) and empty the recovery tank into an approved source to resume operation.

If oil pressure drops, fuel is shut off to the engine, activating an automatic shut-down. Check the engine oil level and fill if necessary. If the oil level is full, try starting the unit normally. If the unit shuts down when the OVR switch is let go of, you may have a faulty oil pressure switch or fuel shut-off solenoid. Consult the Kohler Engine Operation and Maintenance Manual for more information.

Refer also to the Troubleshooting section of this manual for related information.

WARNING!

Do not alter or modify your Big Gulp 3500 in any way. Use only replacement parts authorized by Sapphire Scientific. Modifications or use of unapproved parts could create a hazard and will void your warranty. Contact a Sapphire Scientific service representative at 1-800-932-3030 for assistance.

FREEZE PROTECTION

These instructions for winterizing only applies to units with the optional automatic waste pump installed as seen in the figure below.

WINTERIZING YOUR UNIT

CAUTION

If the waste pump is exposed to freezing weather conditions, the water inside of the pump may freeze, resulting in **SERIOUS DAMAGE** to the impeller. Water freezes at 32° F and 0° C. The following is recommended to prevent this from occurring during the cold weather season:

If possible, store the unit in a heated building when not in use.

WINTERIZING THE UNIT WITH ANTIFREEZE

- A. Close the ball valve leading from the recovery tank to the waste pump.
- B. Locate the winterizing valve and hose as shown in the diagram below. Open the winterizing valve. Insert the winterizing hose into a container with 100% glycol based antifreeze.

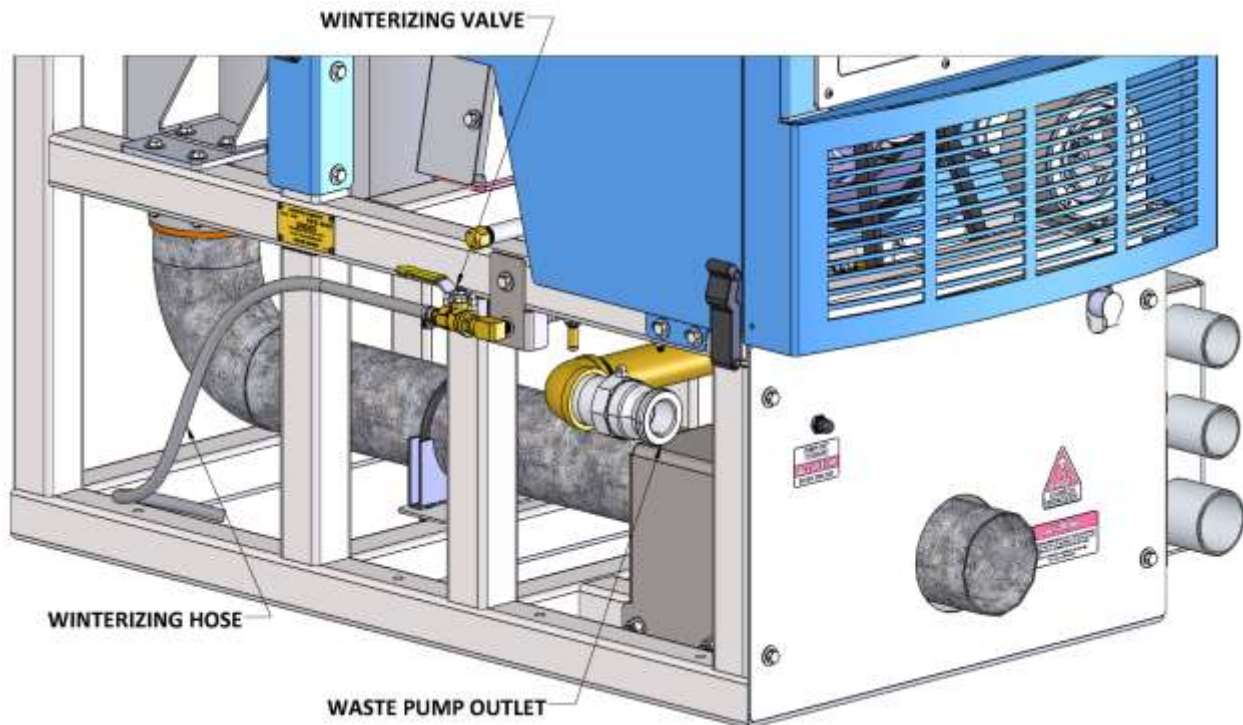

- C. Antifreeze will eject from the waste pump outlet. It is recommended to hook up a hose to the outlet with the open end in a container.
- D. Run the unit on low speed and turn the waste pump on until antifreeze comes out the pump outlet port.
- E. Turn the waste pump off, shut down the unit and close the winterizing valve.

SECTION THREE – OPERATION

Drain the pump between jobs in freezing weather conditions to prevent damaging the waste pump impeller.

 **CAUTION**

Running the pump dry for any length of time will cause damage to the pump impellers and void your warranty.

 **WARNING**

NEVER dispose of waste water or antifreeze in a storm drain, water way or on ground areas. Dispose of antifreeze only in an approved location. Always observe Local, State, and Federal laws when disposing of waste water or antifreeze.

Recover as much antifreeze as possible and store in an approved container. Always reuse or recycle antifreeze.

SECTION FOUR: SERVICE AND MAINTENANCE

MAINTENANCE CHART

DAILY, WEEKLY AND MONTHLY MAINTENANCE CHARTS.....	32
---	----

SERVICE CHART

SERVICE INTERVAL CHARTS.....	33
------------------------------	----

MAINTENANCE

ENGINE.....	35
VACUUM PUMP	36
VACUUM INLET FILTER.....	37
RECOVERY TANK STRAINER BASKETS.....	37
VACUUM HOSES.....	37
DRIVE BELTS, PULLEYS AND HUBS	38

GENERAL SERVICE ADJUSTMENTS

VACUUM RELIEF VALVE	39
---------------------------	----

TROUBLESHOOTING

ENGINE.....	41
VACUUM PUMP	42
WASTE PUMP	42

ROUTINE MAINTENANCE CHART

DAILY MAINTENANCE

Engine	Check engine oil level. (1) Fill to proper level. Do not overfill.
Vacuum Pump	Check vacuum pump oil level. Fill to proper level. Do not overfill. (2)
Vacuum Pump	Spray WD-40 (or Equivalent) into the lubrication cup for 10 seconds.
Vacuum Inlet Filter	Inspect filter, clean and or replace. (2)
Strainer Basket	Empty and clean stainless steel basket in the recovery tank
Recovery Tank	Rinse tank and clean.
Vacuum Hoses	Rinse with fresh water. (2)
Waste Pump (if installed)	Inspect and remove any debris or sediment. (2)

WEEKLY MAINTENANCE

Engine	Check air filter for damaged, dirty or loose parts.
Float Switches	Clean and inspect float switches in the recovery tank.
Visual Inspection	Check for leaks in the equipment.

MONTHLY MAINTENANCE

Engine	Inspect drive belts for wear. Replace as needed.
Engine	Inspect air intake and cooling areas. Clean if required.
Battery	Check fluid level. Fill with distilled water only. Do not overfill.
Battery Terminals	Check vehicle battery terminals. Clean as needed.
Wiring Harness	Check wiring throughout for signs of chafing or wear.
Check fasteners	Check fastener tightness on all components. Tighten as needed.

To maximize the operating life and performance, use only recommended oils, filters and greases.

- (1) Change engine oil and oil filter after first **5 to 8 hours** of operation.
- (2) Or as often as required.
- (3) Inspect after **first week** of operation, and remove any debris present. Inspect again after **2 to 4 weeks**.

SERVICE CHART

SERVICE INTERVALS – EVERY 100 HOURS

Engine	Change engine and oil filter. (1)
Vacuum Relief Valve	Check and adjust vacuum relief valve up to 13" Hg if needed.
Belts	Re-tension all belts (2)
Battery	Clean battery terminals

SERVICE INTERVALS – EVERY 200 HOURS

Engine	Clean engine air filter.
Engine	Check spark plugs and clean if necessary.

SERVICE INTERVALS – EVERY 500 HOURS

Engine	Replace inline fuel filter. (3)
Pulleys and Hubs	Check pulleys and hubs for proper torque. (4)

SERVICE INTERVALS – EVERY 1000 HOURS

Engine	Replace spark plugs
Engine	Replace air filter element.
Belts	Replace all belts.
Vacuum Pump	Drain, flush and replace oil. (5)

To maximize the operating life and performance, use only recommended oils, filters and greases.

- (1) Change engine oil and oil filter after first **5 to 8 hours** of operation.
- (2) Re-tension belts after **first 25 hours**, then every **100 hours** of operation after.
- (3) Or every 6 months, whichever comes first.
- (4) Check pulley and hub set screws after **first 50 hours** of operation, and again at **100 hours** of operation.
- (5) Every **1000 hours** or **yearly**, whichever comes first.

MAINTENANCE

This section of the operator’s manual contains the service and maintenance information for the Big Gulp 3500 unit. A planned preventative maintenance program will ensure that your Big Gulp 3500 has optimum performance, long operating life, and a minimum amount of down time.

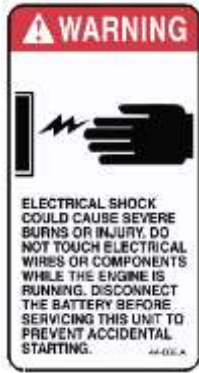

WARNING

DO NOT attempt to service this unit while it is running. High speed parts as well as high temperature components may result in severe injury, severed limbs, or fatality.

NOTE: Refer to the hour meter as a guide for coordinating a maintenance schedule.

ENGINE

Check engine oil daily. Ensure that the proper oil level is maintained. **NEVER** overfill.

Change the oil after the first 5 to 8 hours of operation. Thereafter, change oil filter every 50 to 100 hours of operation.

Note: Use only Kohler brand oil filters. Use of any other type of oil filter will void engine warranty.

Use high-quality oil of at least API (American Petroleum Institute) service class SG, SH, SJ or higher. **Do not use additives.** A 20W-50 synthetic blend may be used after 50 hours of operation for a new or rebuilt engine to allow the piston rings to properly seat. It is never recommended to extend oil change intervals past 100 hours

Engine Oil Capacity	2.8 L 2.9 US qts
---------------------	---------------------

Tightening Torque	
Drain Plug	32.4 – 37.3 N·m 3.3 – 3.8 kgf·m 23.9 – 27.5 lbf·ft

NOTE: Using lower service class oil or extending oil change intervals longer than recommended can cause engine damage.

Check the spark plugs every **200 hours** and clean if necessary. Replace spark plugs every **1000 hours**. **NEVER** sandblast spark plugs. Spark plugs should be cleaned only by scraping or wire brushing.

Clean the engine air filter element every **200 hours**. Replace the element every **1000 hours**.

NOTE: Additional engine service information can be obtained from the provided Kohler Operation and Maintenance manual. If service or repair is required, contact an authorized Kohler Service Center. They will require the serial number of the engine.

VACUUM PUMP

NOTE: Refer to the provided Vacuum Pump Operation and Service Manual for specific instructions.

Lubrication: Sapphire Scientific *requires* that you use only AEON PD-XD Synthetic vacuum pump Lubricant in both sides of the vacuum pump for all operating temperatures. AEON PD-XD is formulated specifically for positive displacement vacuum pump service to provide maximum vacuum pump protection at any temperature.

NOTE: AEON PD-XD (Part # 13-004) is the only oil that Sapphire Scientific puts in the vacuum pump at the factory. Adding petroleum oil to synthetic oil is **NOT** recommended.

Check the oil level **daily** on both sides to ensure they are at the proper level. Too little oil will damage and ruin the bearings and gears. Too much oil will result in overheating.

NOTE: Two drains are on your vacuum pump. Ensure that **BOTH** sides of the vacuum pump are filled to their proper level when servicing.

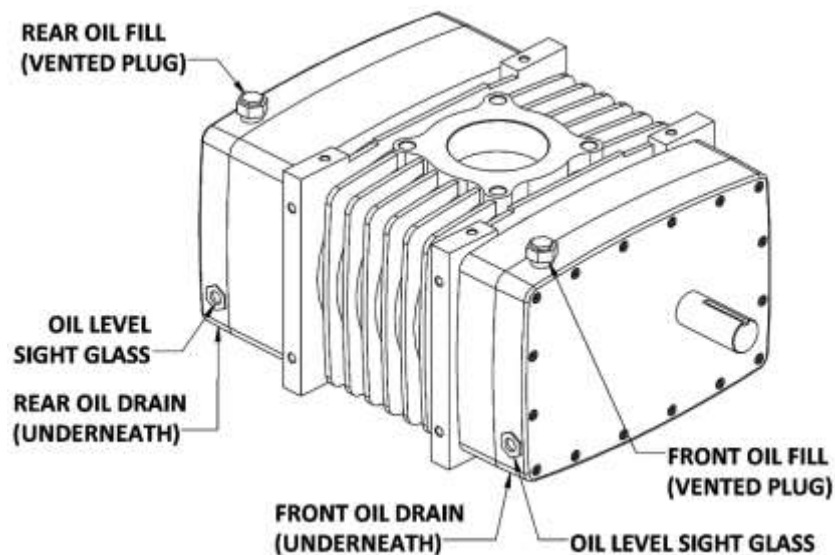

A lubrication cup has been provided at the front of the console, to prevent rust from building up inside of the vacuum pump.

Plug the vacuum ports and spray a water displacement/lubricant into the vacuum lubrication cup for 10 seconds. This procedure should be done at the end of **every working day**.

Drain, flush and replace the oil every 1000 **hours or yearly, whichever comes first**.

VACUUM INLET FILTER

The vacuum inlet filter in the recovery tank should be inspected and cleaned **daily**.



When removing the vacuum inlet filter, grip the plastic hexagon section of the filter. Grasping filter by the screen will damage or destroy the filter. Applying grease to the threads will allow easier removal of filter when cleaning or replacement is required.

RECOVERY TANK STRAINER BASKET

The recovery tank strainer should be emptied and cleaned on a **daily** basis.

VACUUM HOSES

To ensure maximum hose life, Sapphire Scientific recommends that you wash out the hoses with fresh water **daily**.

DRIVE BELTS, PULLEYS AND HUBS

Check pulley set screws and hub screws after the first **25 hours** of operation and again at **100 hours**. Re-torque these screws with a torque wrench. Follow the torque values on the following table. Check pulley set screws and hub screws every **500 hours** thereafter.

NOTE: Ensure belts are properly tensioned after checking the torque values. Use Gates EPDM belts.



Ensure that when you re-torque the screws, you use a clockwise pattern and continue until the proper torque is achieved.

TORQUE VALUES		
Component	Inch/lbs	Foot/lbs
Vacuum Pump Hub #38-032	180	15

BELT REPLACEMENT PROCEDURES FOR THE BIG GULP 3500

1. Disconnect the negative battery terminal.
2. Remove the hose from the recovery tank to the vacuum pump.
3. Remove hoods.
4. Remove top panel.
5. Remove left and right hand belt guards.
6. Remove the hose between the blower and the silencer.
7. Loosen all 4 blower mounting nuts.
8. Slide the blower back (away from engine).
9. Lower front two nuts located under the front of the blower mounting plate approximately 1/2".
10. Tip the back of the blower up.
11. Remove all belts. Install new belts.
12. Reverse procedures to install new belts, lower the back of the blower and slide the blower forward, raising the front two nuts to the same height as the rear nuts.
13. Tighten all nuts to tension belts, checking for proper tension and alignment. Use a belt gauge to check tension. Set deflection to 1/8"; 10 to 12 lbs. of tension.
14. Check pulleys for alignment using a straight edge (example: 1/2" key stock bar). Make sure pulley flange touches on 2 places on each pulley (4 total).

(Estimated time 2 hours)

GENERAL SERVICE ADJUSTMENTS



DO NOT attempt to service this unit while it is running. High speed parts as well as high temperature components may result in severe injury, severed limbs, or fatality.

ENGINE SPEED

1. To adjust the engine RPM, refer to the Kohler Engine Operation and Service Manual for specific instructions.



DO NOT attempt to adjust without a tachometer and NEVER adjust the engine above 3000 RPM.

VACUUM RELIEF VALVE

With the unit running at high speed, block off the airflow at the vacuum inlet port and read the vacuum gauge. If adjustment is required, shut the unit down and adjust the locking nut tension on the vacuum relief valve. Re-start the unit and read the vacuum gauge. Repeat this process until the vacuum relief valve opens at 13" Hg. Always ensure the lock nut is retightened and the cotter pin is replaced.



To reduce the risk of injury: NEVER obstruct the vacuum port with your hand or other body part. Keep hair, loose clothing and all body parts away from vacuum port openings while unit is in operation.

TROUBLESHOOTING



DO NOT attempt to service this unit while it is running. High-speed parts as well as high temperature components may result in severe injury, severed limbs or fatality.

This section of the operator's manual describes how to look for and repair malfunctions, which may occur. Accurate troubleshooting is based on a thorough and complete understanding of the ENGINE, **VACCUM**, **SAFETY** and **WIRING** systems featured in this unit.

If there are malfunctions occurring on this unit which you do not understand, refer back to the **OPERATION** section of this manual and review **SYSTEM**.

ENGINE TROUBLESHOOTING**ENGINE WILL NOT START (STARTER DOES NOT TURN OVER)**

PROBABLE CAUSE	SOLUTION
Main circuit breaker on the control panel has been tripped.	After inspecting the unit to determine the cause of the tripped breaker, press the reset button.
Loose or corroded battery connections.	Clean, tighten or replace the battery terminals.
Dead battery.	Recharge or replace battery
Defective starter motor.	Test the starter motor. Replace if necessary.
Vacuum pump seized.	Refer to the vacuum pump manufacturer service and repair manual.

STARTER TURNS OVER BUT ENGINE WILL NOT START

PROBABLE CAUSE	SOLUTION
Recovery tank is full.	Empty the recovery tank.
Defective fuel pump.	Replace the fuel pump.
Loose or broken wires leading to the recovery tank float switch.	Repair or replace any broken electrical connections.
Defective float switch inside recovery tank.	Check switch for proper operation. Replace if necessary.
Oil pressure switch (located on engine), fuel shut-off solenoid (located on engine).	Test these components. If any are defective, replace. Consult the Kohler Engine Operation and Maintenance Manual.
Engine is malfunctioning.	Refer to Kohler Engine Operation and Maintenance Manual.

ENGINE STOPS RUNNING DURING NORMAL OPERATION

PROBABLE CAUSE	SOLUTION
Engine is out of gasoline.	Check the fuel tank.
Recovery tank is full.	Empty recovery tank.
Main circuit breaker on the control panel has been tripped.	After inspecting the unit to determine the cause of the tripped breaker, press the reset button.
Defective fuel pump.	Replace fuel pump.
Defective float switch inside recovery tank.	Check switch for proper operation. Replace if necessary.
Oil pressure switch on engine has shut down due to insufficient oil pressure.	Refer to the Kohler Engine Operation and Maintenance Manual. DO NOT restart the engine until the cause is determined and corrected.
No ignition in the engine or the engine is malfunctioning.	Refer to the Kohler Engine Operation and Maintenance Manual.

VACUUM PUMP TROUBLESHOOTING**LOSS OF VACUUM** (while cleaning, engine RPM is normal but vacuum is lower than expected)

PROBABLE CAUSE	SOLUTION
Vacuum gauge is giving an improper reading.	Examine the tubing between the vacuum relief valve and the vacuum gauge and remove any blockage.
Vacuum hose(s) is damaged, causing a suction leak.	Inspect hose(s), repair or replace.
Recovery tank gaskets not sealing properly, not positioned properly.	Inspect the gasket. Repair seal or replace Re-position lid(s).
Plugged vacuum hose or vacuum plumbing between vacuum inlet and strainer basket.	Unplug vacuum hose or inlet plumbing.
Recovery tank filter or strainer basket is plugged.	Clean or replace filter. Clean strainer basket.
Loose vacuum pump drive belts.	Tighten the drive belts.
Recovery tank drain valve is damaged or left open, causing a vacuum leak.	Drain the recovery tank. Close drain valve, if open. Replace valve if defective.
Vacuum relief valve requires adjustment or has a vacuum leak due to damaged diaphragm.	Re-adjust the vacuum relief valve. If the vacuum does not increase, remove and inspect the relief valve diaphragm. If damaged, replace.
Vacuum pump is worn out.	Replace the vacuum pump.

EXCESSIVE VACUUM (while cleaning, engine RPM is normal but vacuum is higher than expected)

PROBABLE CAUSE	SOLUTION
Vacuum relief valve requires adjustment.	Readjust vacuum relief valve to 13" Hg.

WASTE PUMP (IF INSTALLED) TROUBLESHOOTING**WASTE PUMP IS MALFUNCTIONING**

PROBABLE CAUSE	SOLUTION
Defective waste pump float switch.	Replace float switch.
Broken impeller in pump.	Replace impeller.
Pump out circuit breaker on instrument panel has tripped.	After inspecting waste pump to determine the cause of the overloaded circuit, press reset button.
Ball valve closed.	Open valve.
Weak battery.	Charge or replace battery. Check charging station.

SECTION FIVE: PARTS AND ACCESSORIES

ILLUSTRATED PARTS LISTING

CONSOLE ASSEMBLY	44
FRAME AND ENCLOSURES	47
INSTRUMENT PANEL	50
LOWER FRONT PANEL	51
ENGINE	52
BELT GUARD ASSEMBLY	53
VACUUM PUMP	54
VACUUM RELIEF VALVE	55
BELT GUARD BLOWER.....	56
RECOVERY TANK	57
DECALS	58

ELECTRICAL

3500 ELECTRICAL DIAGRAM	59
3501 ELECTRICAL DIAGRAM	60

OPTIONAL EQUIPMENT (3501)

WASTE PUMP ASSEMBLY (OPTIONAL).....	61
WINTERIZING KIT (FOR OPTIONAL WASTE PUMP)	62

FUEL

FUEL HOOK-UP KITS	63
FUEL LINES/PUMP INSTALLATION	67

70-3500BB, CONSOLE, BIG GULP 3500 (FIG. 1 OF 2)

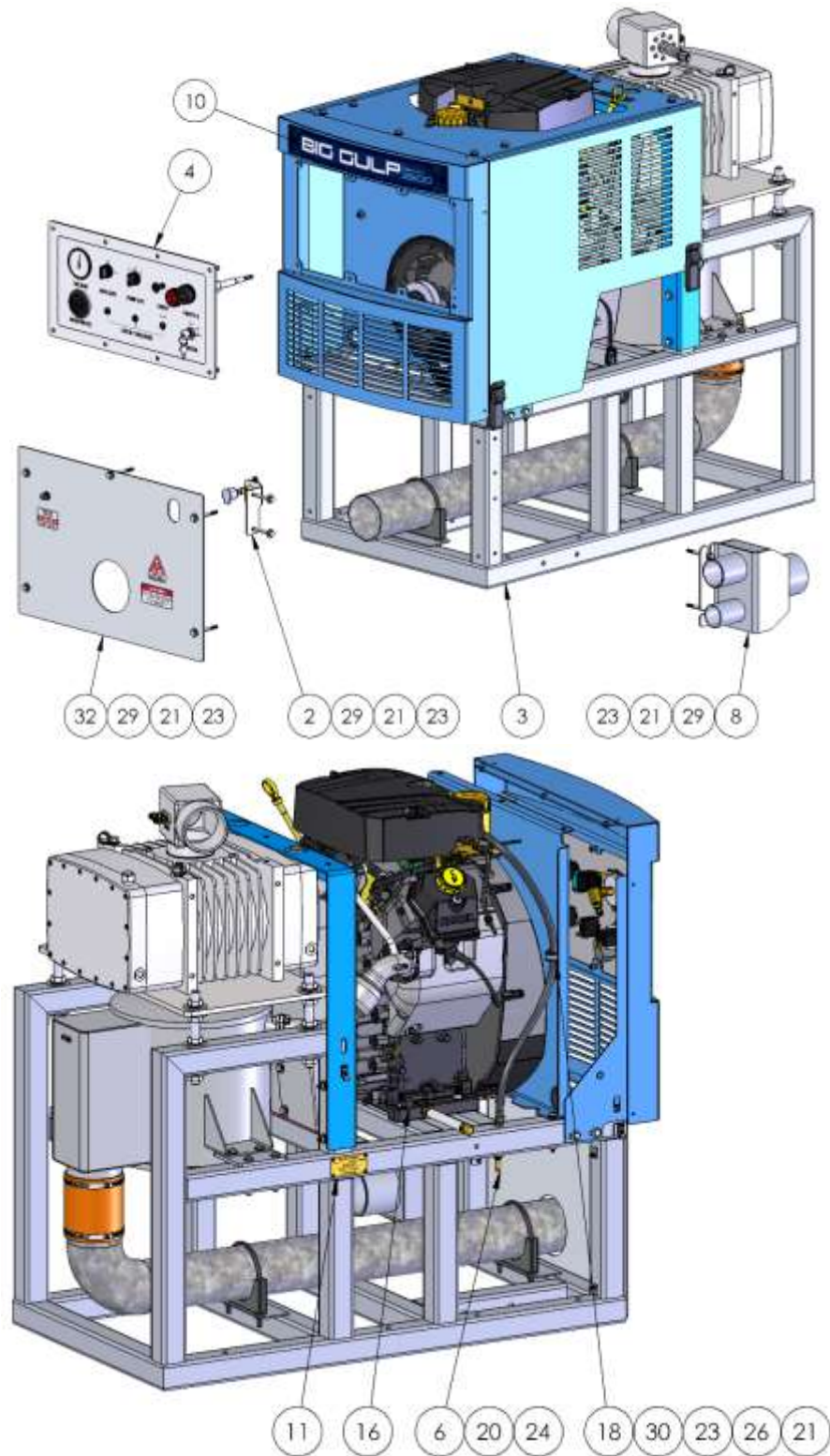

70-3500BB, CONSOLE, BIG GULP 3500 (FIG. 2 OF 2)

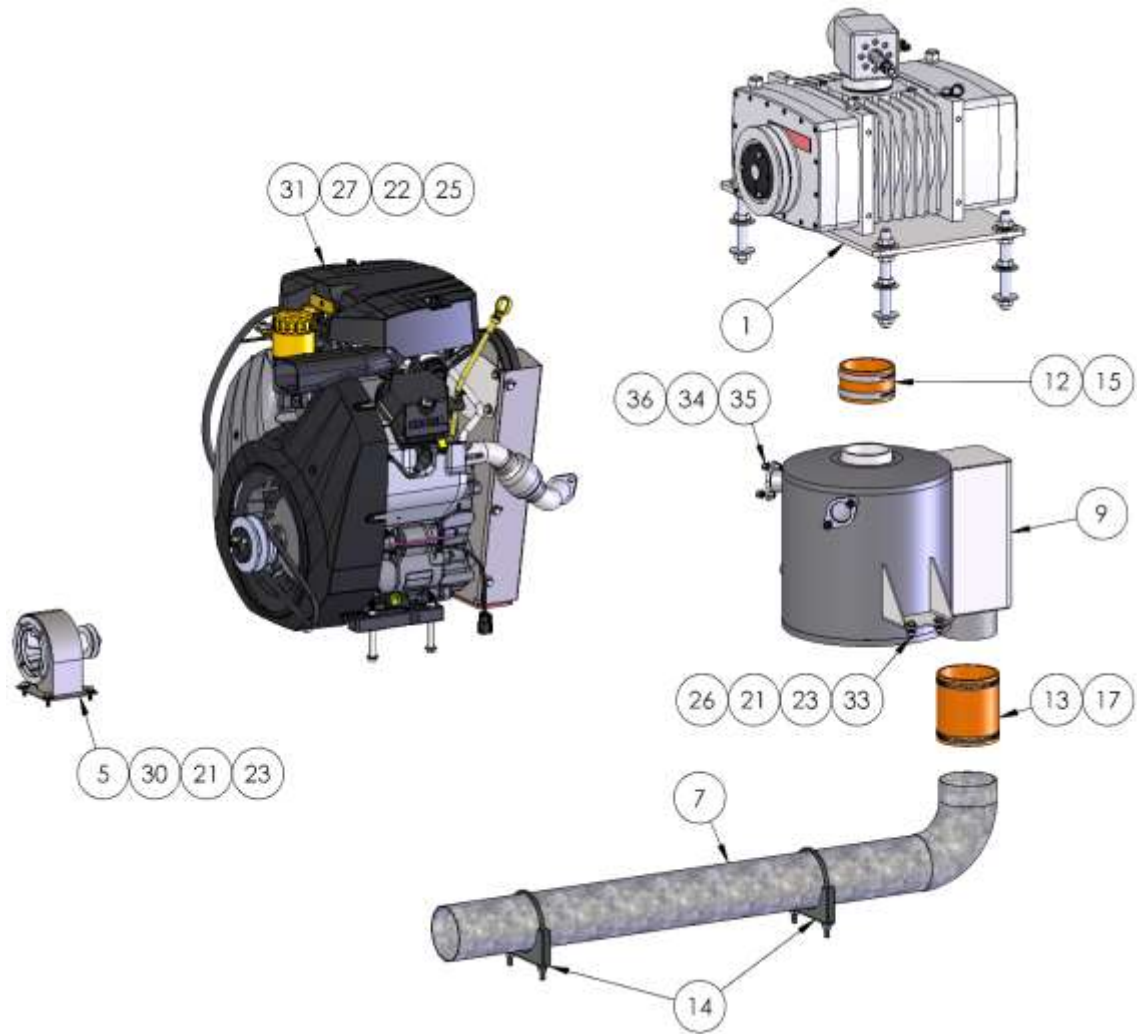

70-3500BB, CONSOLE, BIG GULP 3500 – BOM TABLE

1	39	44-187	DECAL, CO DANGER TRIANGLE
1	38	44-278	DECAL, WARNING CA PROP 65
1	37	44-277	DECAL, MOMENTARY PUMP OVERRIDE
4	36	11-005	NUT, 5/16-18 ZINC
4	35	10-074	SCREW, MACH 5/16-18 X 1 S0CHD SS
4	34	12-016	LKWSR, 5/16 ZINC
4	33	10-026	SCREW, MACH 1/4-20 X 1 HXHD
1	32	69-814	ASSY, LOWER FRONT PANEL
1	31	69-599	ASSY, ENGINE
5	30	10-025	SCREW, MACH 1/4-20 X 3/4 HXHD GRD5
9	29	10-028	SCREW, MACH 1/4-20 X 2-3/4 HXHD
1	28	10-035	SCREW, 1/4 X 1 HWH TEKS 3
4	27	10-139	BOLT, 3/8-16 X 4 GRADE 5 HEX
5	26	11-004	NUT, 1/4-20 ZINC
4	25	11-019	NUT, 3/8-16 NYLOK
1	24	11-088	NUT, 7/16-20 THIN NYLOK ZPS
23	23	12-012	WASHER, FLAT 1/4 USS
8	22	12-013	WASHER, FLAT 3/8 SAE
18	21	12-015	LKWSR, 1/4 ZINC
1	20	12-021	WASHER, FLAT, 7/16 ZINC
1	19	14-003	CLAMP, WIRE CUSHION 1.00 ID X 1/4 BOLT
1	18	14-004	CLAMP, WIRE CUSHION 3/4 ID X 1/4 BOLT
2	17	14-008	CLAMP, HOSE #72
1	16	14-023	CLAMP, 3/4 ID VINYL COVERED
2	15	14-050	CLAMP, HOSE 4 1/2 TO 2 1/2 HD SS
2	14	14-064	CLAMP, MUFFLER 4 IN
4.75 IN	13	16-109	HOSE, 4.0 IN ID X 3FT SILICONE 550F
2.25 IN	12	16-121	HOSE, 3.5 IN ID X 3FT SILICONE
1	11	44-124	PLATE, SERIAL BIG GULP 3500BB
1	10	44-125	DECAL, PRODUCT BIG GULP 3500
1	9	61-1028	WELDMENT, SILENCER
1	8	61-714	WELDMENT, DUAL VAC BRACKET
1	7	61-788	WELDMENT, EXHAUST TUBE
1	6	66-359	FITTING, 1/4 X 5/16 FUEL LINE MANIFOLD
1	5	69-184	ASSY, BELT GUARD BLOWER
1	4	69-195	ASSY, CONTROL PANEL
1	3	69-598	ASSY, FRAME & ENCLOSURES
1	2	69-389	ASSY, OIL CUP BRACKET
1	1	69-597	ASSY, VACUUM BLOWER
QTY	ITEM	PART NO.	DESCRIPTION

69-598, ASSEMBLY, FRAME AND ENCLOSURES (FIG. 1 OF 2)

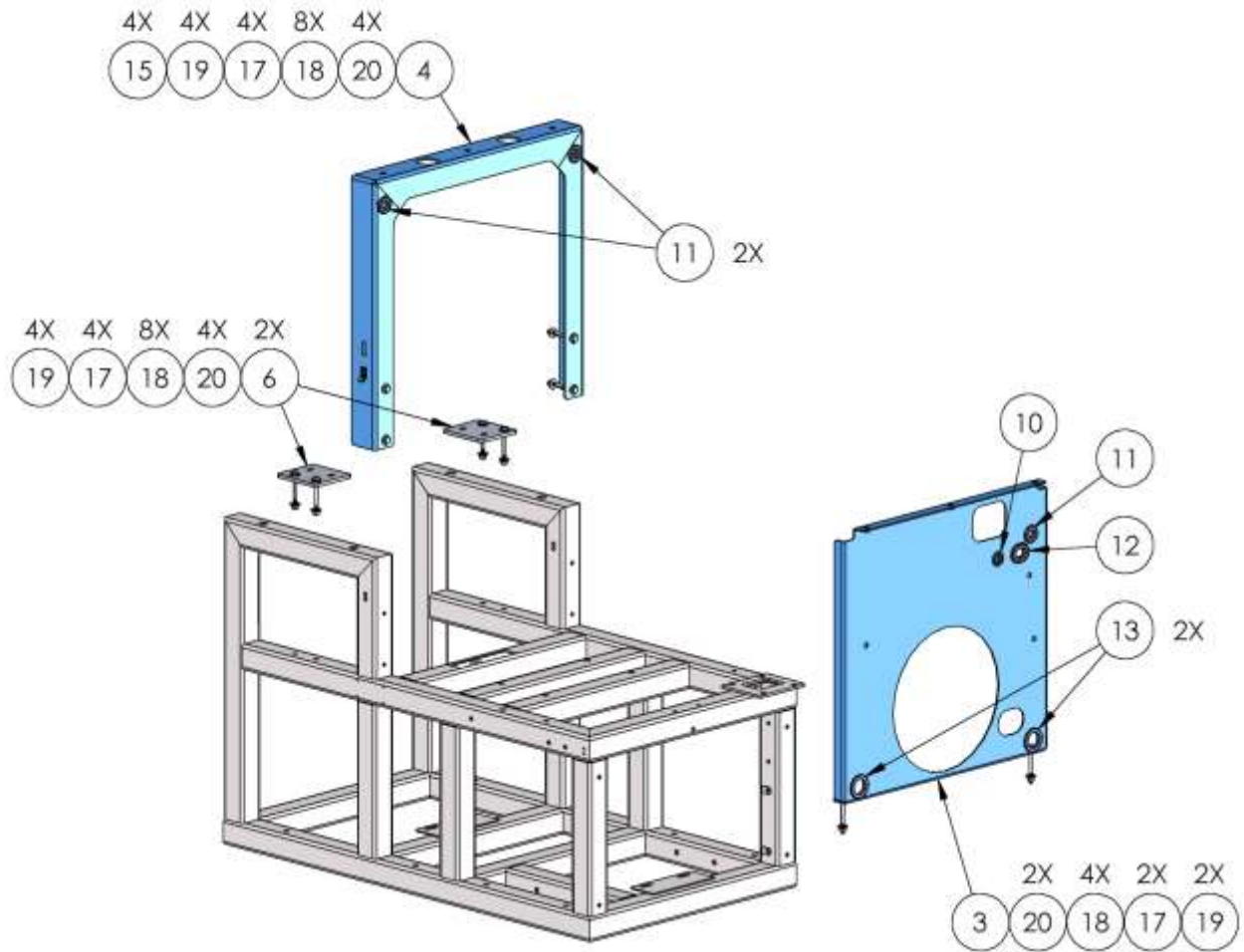

69-598, ASSEMBLY, FRAME AND ENCLOSURES (FIG 2 OF 2)

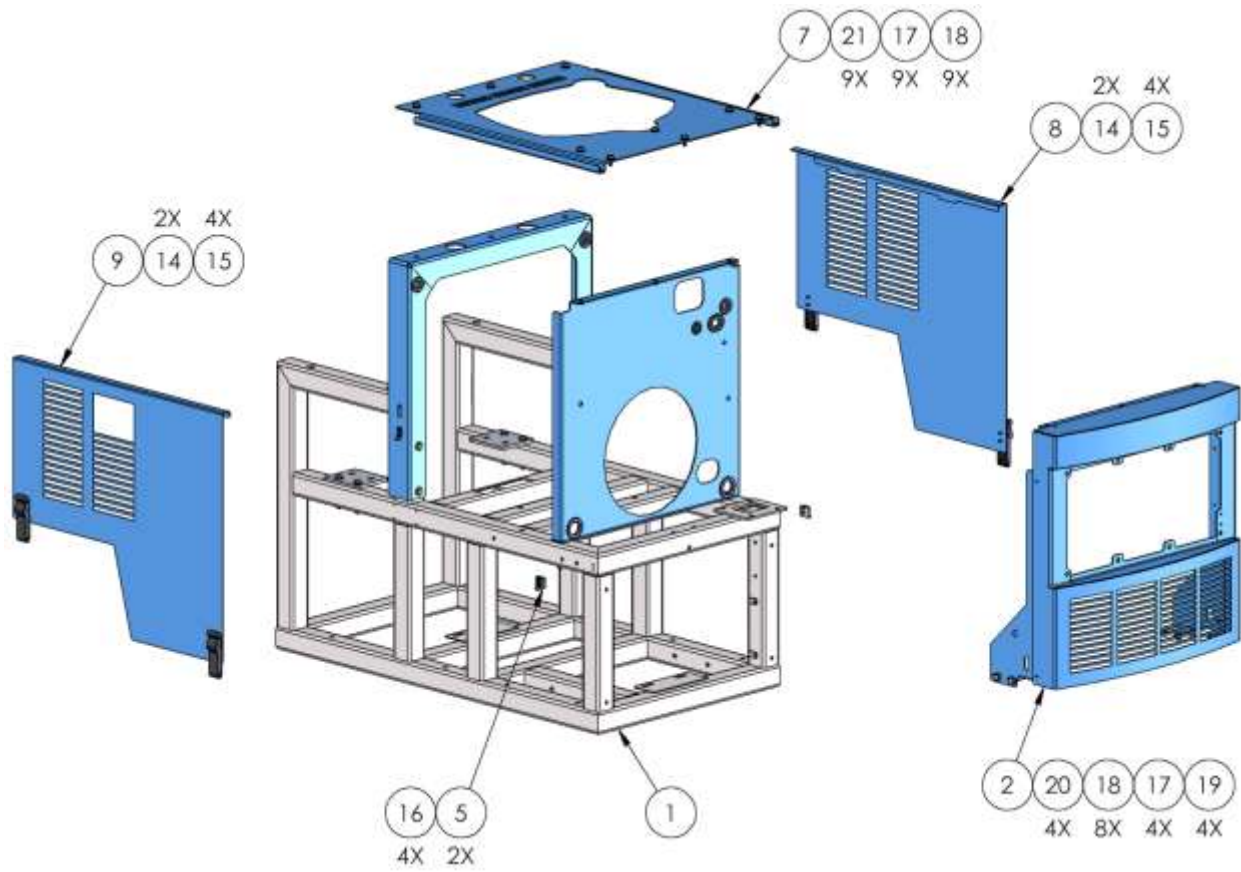

69-598, ASSEMBLY, FRAME AND ENCLOSURES – BOM TABLE

9	21	10-025	SCREW, MACH 1/4-20 X 3/4 HXHD GRD5
14	20	10-028	SCREW, MACH 1/4-20 X 2-3/4 HXHD
14	19	11-004	NUT, 1/4-20 ZINC
37	18	12-012	WASHER, FLAT 1/4 USS
23	17	12-015	LKWSR, 1/4 ZINC
4	16	14-085	RIVET, 5/32 X .312 HD .251-.375 GRIP SS
12	15	14-086	RIVET, 5/32 X .312 HD .062-.125 GRIP SS
4	14	40-034	LATCH, DRAW SS CONCEALED MOUNT
2	13	41-020	GROMMET, 1-7/8 OD X 1-1/4 ID
1	12	41-033	GROMMET, 1 ID X 1-3/4OD
3	11	41-071	GROMMET, 1-3/8" OD X 3/4" ID X 1/8" PANEL
1	10	41-096	GROMMET, 1-1/8 OD X 5/8 ID X 1/8 PANEL
1	9	58-662	PNL, LEFT SIDE
1	8	58-663	PNL, RIGHT SIDE
1	7	58-681	PANEL, TOP 22IN
2	6	58-685	PLATE, SILENCER SUPPORT
2	5	58-699	PLATE, LATCH SPACER
1	4	61-1045	WELDMENT, REAR BRACE 22IN
1	3	61-1047	WELDMENT, AIR DAM 22IN
1	2	61-1057	WELDMENT, FRONT BEZEL
1	1	61-778	WELDMENT, FRAME
QTY	ITEM	PART NO.	DESCRIPTION

69-195, ASSEMBLY, INSTRUMENT PANEL

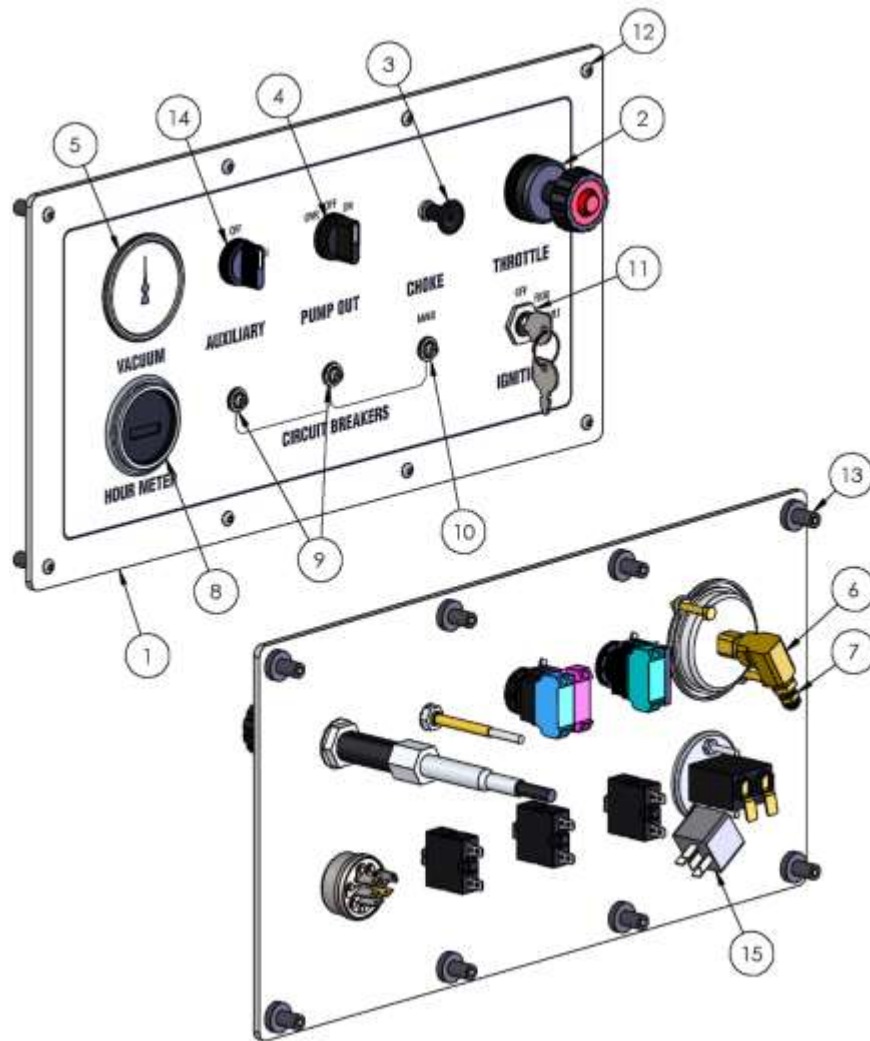

1	15	34-010	RELAY, ENG.SHTDWN12V20/30AMP
1	14	29-016	SWITCH, ROTARY NON-ILLUMINATED
8	13	11-002	NUT, WELL G 10-32
8	12	10-016	SCREW, MACHINE 10-32 X 1 SOCHD SS
1	11	29-047	SWITCH, ENGINE STARTER
1	10	30-007	BREAKER, 30 AMP
2	9	30-008	BREAKER, 20 AMP
1	8	26-033	HOURMETER, HOBBS CHROME BEZEL
1	7	21-433	CONN, 1/4 P X 1/4 POLY
1	6	21-037	ELL, 1/4 IN. BRASS
1	5	26-044	GAUGE, VACUUM 2.5 IN 0-30 IN/HG
1	4	29-070	SWITCH, ROTARY, 3 POS, SR FROM LEFT, 1 NO, 1 NC
1	3	40-032	CABLE, CHOKE
1	2	40-031	CABLE, THROTTLE
1	1	58-386	PANEL, INSTRUMENT BIG GULP
QTY	ITEM	PART NO.	DESCRIPTION

69-814, ASSEMBLY, LOWER FRONT PANEL

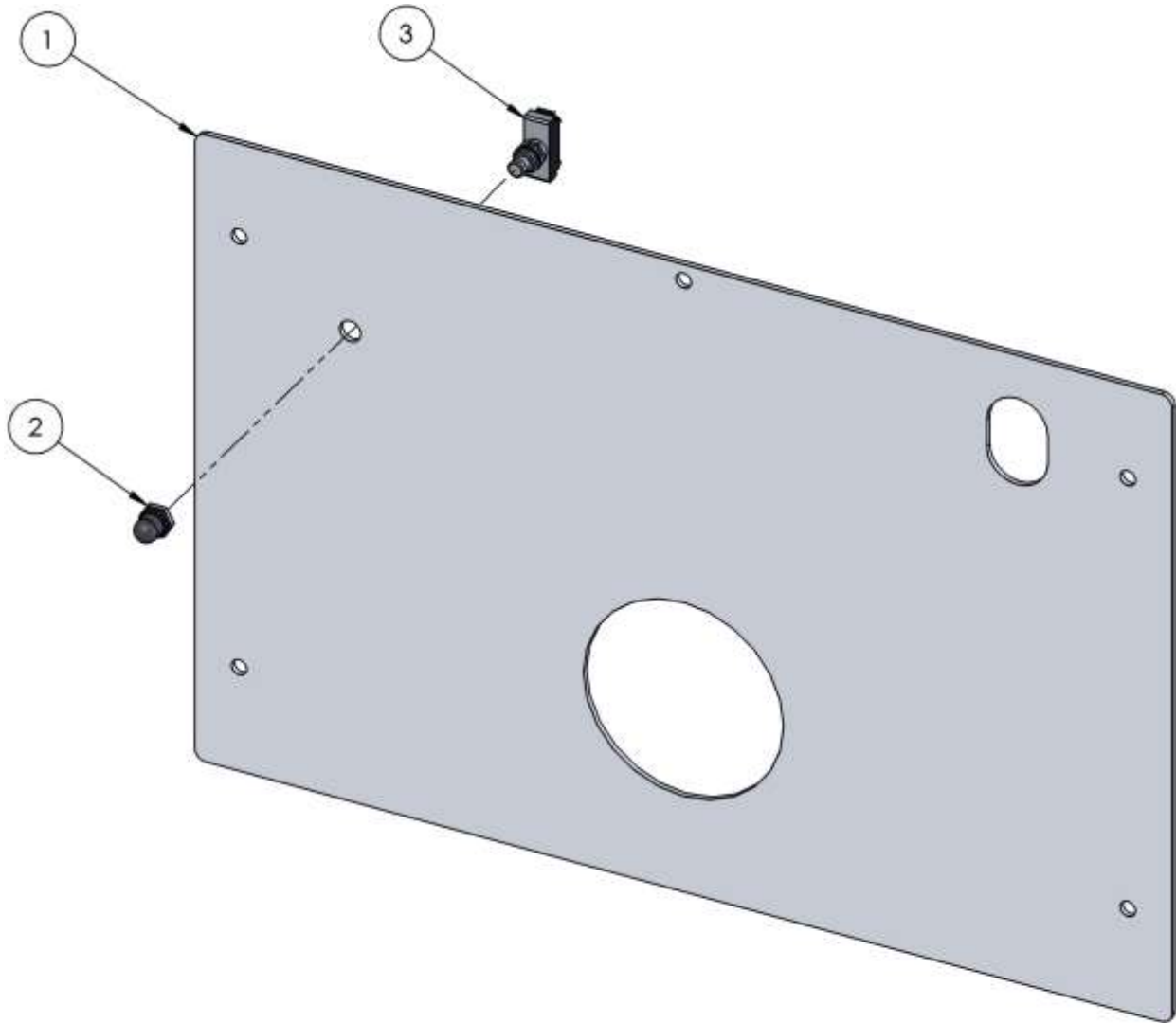

1	3	29-037	SWITCH, PUSH BUTTON SELECTA
1	2	29-038	SWITCH, BOOT PUSH BUTTON
1	1	58-702	PANEL, LOWER FRONT
QTY	ITEM	PART NO.	DESCRIPTION

69-599, ASSEMBLY, ENGINE

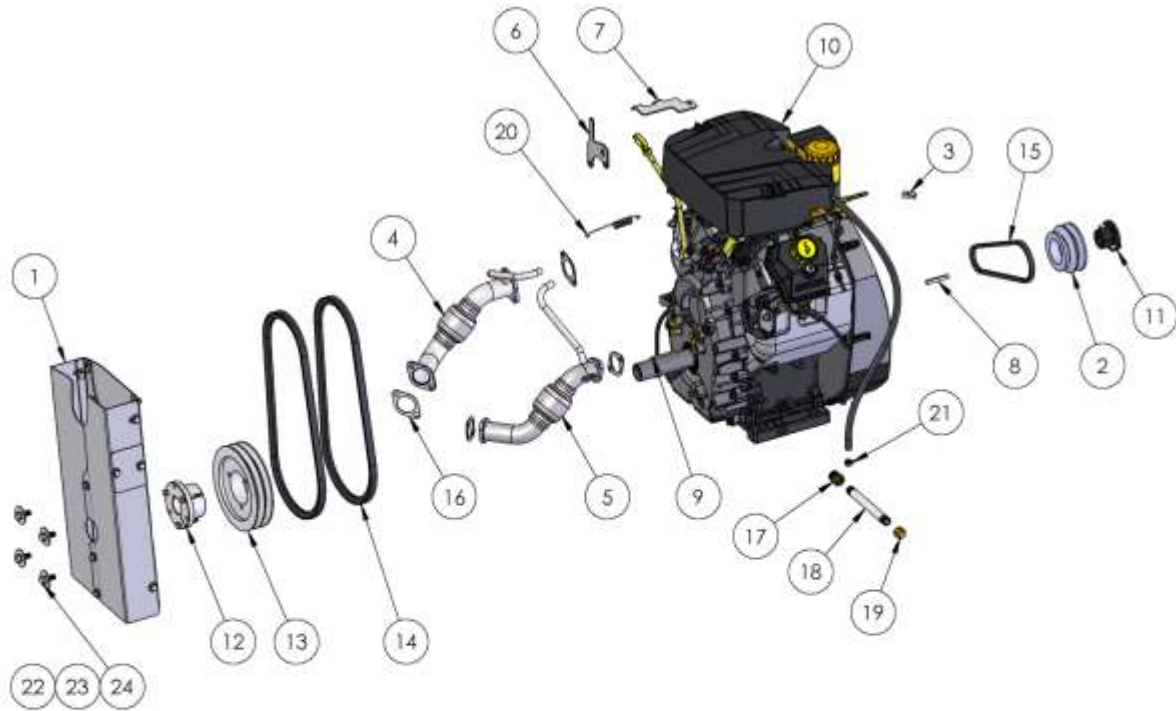

QTY	ITEM	PART NO.	DESCRIPTION
1	12	38-034	HUB, 1-7/16 4JTU56
1	11	38-052	BUSHING, BROWNING H X 1.125
1	10	45-041	ENGINE, KOHLER 38HP BIG BLOCK CH980
2.25 IN	9	55-008	KEYSTOCK, SS 304 3/8 SQUARE x 12 FT
2.00 IN	8	55-031	KEYSTOCK, HR 1/4 SQUARE X 12 FT
1	7	58-678	BRACKET, CHOKE CABLE MOUNT
1	6	58-686	PLATE, CHOKE SPRING MOUNT
1	5	61-1060	WELDMENT, ENGINE EXHAUST LS
1	4	61-1061	WELDMENT, ENGINE EXHAUST RS
1	3	66-122	RETAINER, CABLE
1	2	66-367	PULLEY, ENGINE FRONT
1	1	69-588	ASSY, BELT GUARD

QTY	ITEM	PART NO.	DESCRIPTION
1	25	16-104	HOSE, FUEL 1/4 30R9 FUEL INJECTION
4	24	10-029	SCREW, MACH 3/8-16 X 1 HXHD
4	23	12-014	LKWSR, 3/8 ZINC
4	22	12-049	WASHER, 3/8 X 1-1/2 FENDER ZINC
1	21	14-067	CLAMP, HOSE 1/4 IN
1	20	15-054	SPRING, CHOKE RETURN
1	19	21-326	CAP, 3/8 NPT BRASS
1	18	21-329	NIPPLE, 3-8 NPT X 6 SS
1	17	21-371	BUSHING, 1/2 NPT X 3/8 NPT HEX BRASS
4	16	36-485	GASKET, ENGINE EXHAUST SLOTTED
1	15	37-067	BELT, 3L240
2	14	37-098	BELT, 5VX422 GATES EPDM
1	13	38-028	PULLEY, 5V710SK 2G

69-588, ASSEMBLY, BELT GUARD

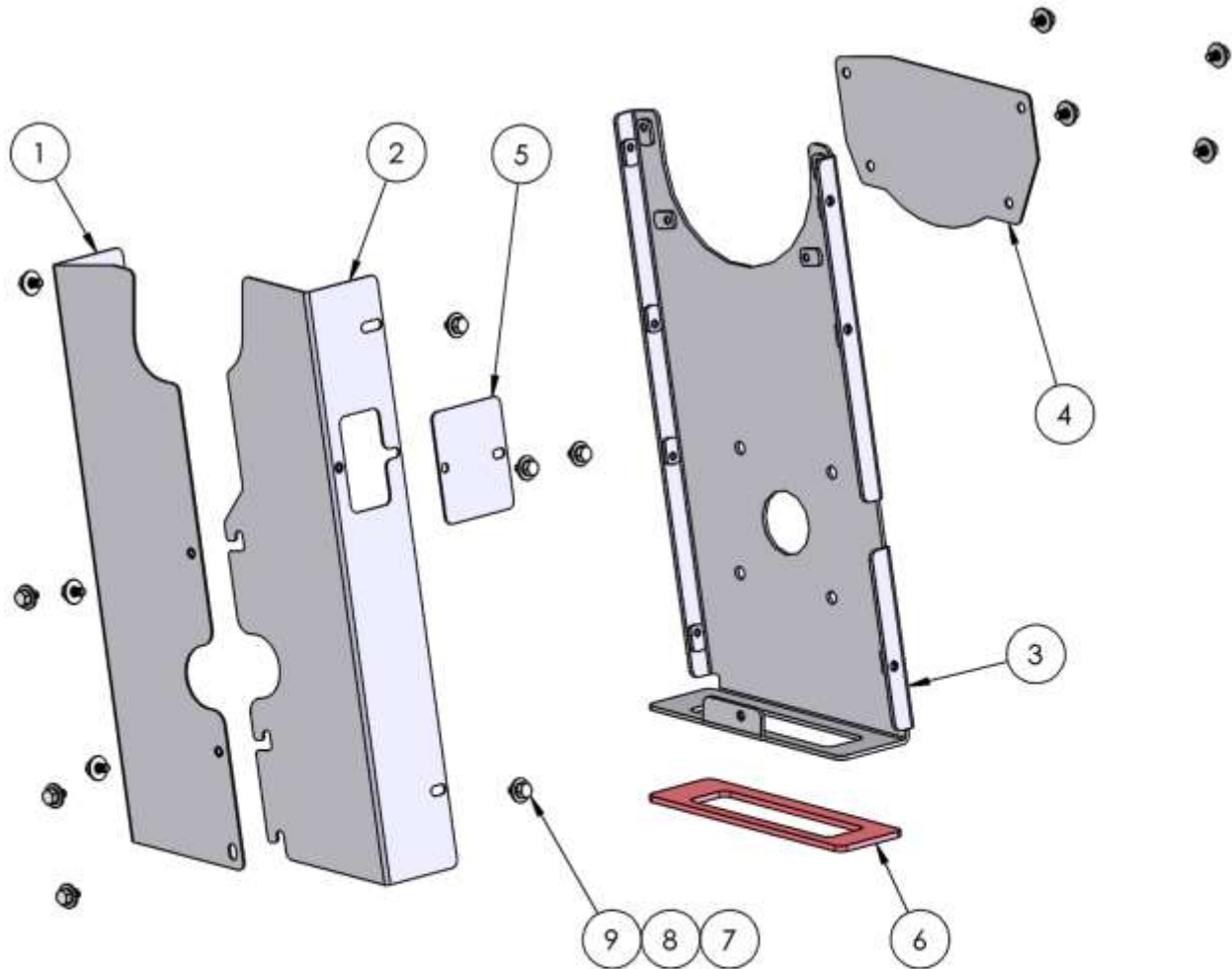

14	9	10-006	SCREW, MACH 1/4-20 X 1/2 HEXHD
14	8	12-012	WASHER, FLAT 1/4 USS
14	7	12-015	LKWSR, 1/4 ZINC
1	6	41-155	GASKET, BELT GUARD
1	5	58-403	PLATE, BELT GUARD INSPECTION COVER
1	4	58-673	PLATE, PULLEY COVER
1	3	61-1012	WELDMENT, BELT GUARD MOUNT
1	2	61-1013	WELDMENT, BELT GUARD LS
1	1	61-1075	WELDMENT, BELT GUARD RS
QTY	ITEM	PART NO.	DESCRIPTION

69-597, ASSEMBLY, VACUUM PUMP

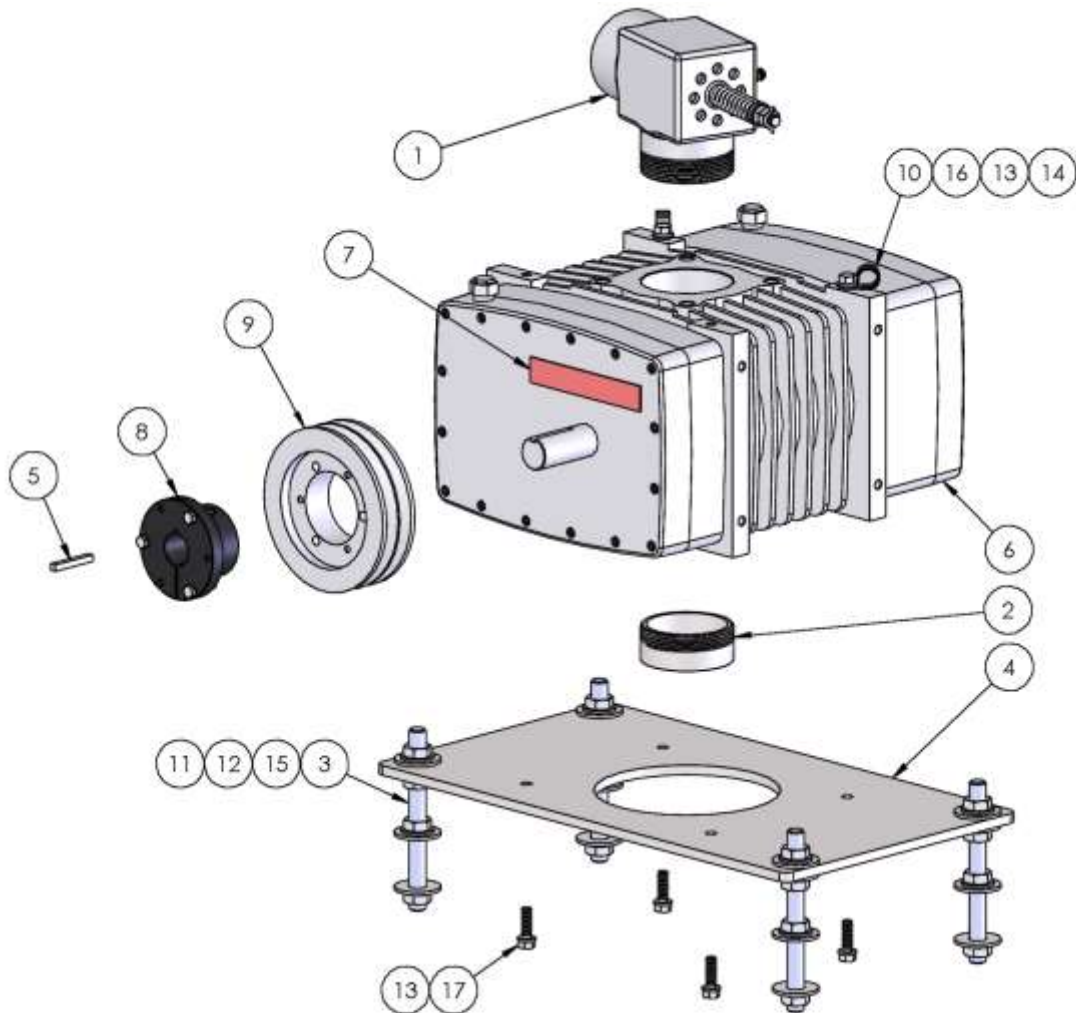

QTY	ITEM	PART NO.	DESCRIPTION
1	8	38-032	HUB, SK 1.25
1	7	41-156	GASKET, .062 SILICONE W/PSA
1	6	46-070	VACUUM PUMP, TRIFLOW 408 HORIZ RH CW
1	5	55-031	KEYSTOCK, HR 1/4 SQUARE X 12 FT
1	4	60-2019	PLATE, VACUUM PUMP MOUNT
4	3	66-227-04	THREADED ROD, .625-18 UNF 2A X 7.0 IN
1	2	66-449	NIPPLE, BLOWER OUTLET
1	1	69-392	ASSY, VAC BREAK

QTY	ITEM	PART NO.	DESCRIPTION
4	17	10-004	SCREW, MACH 3/8-16 X 1-1/4 HEXHD
2	16	10-157	SCREW, MACH 3/8-16 X 1/2 HH ZP
16	15	11-062	NUT, 5/8-18 JAM
2	14	12-013	WASHER, FLAT 3/8 SAE
6	13	12-014	LKWSR, 3/8 ZINC
16	12	12-039	WASHER, LOCK, .625
16	11	12-040	WASHER, FLAT .625 USS
2	10	14-023	CLAMP, 3/4 ID VINYL COVERED
1	9	38-027	PULLEY, 5V630SK

69-392, ASSEMBLY, VACUUM RELIEF VALVE

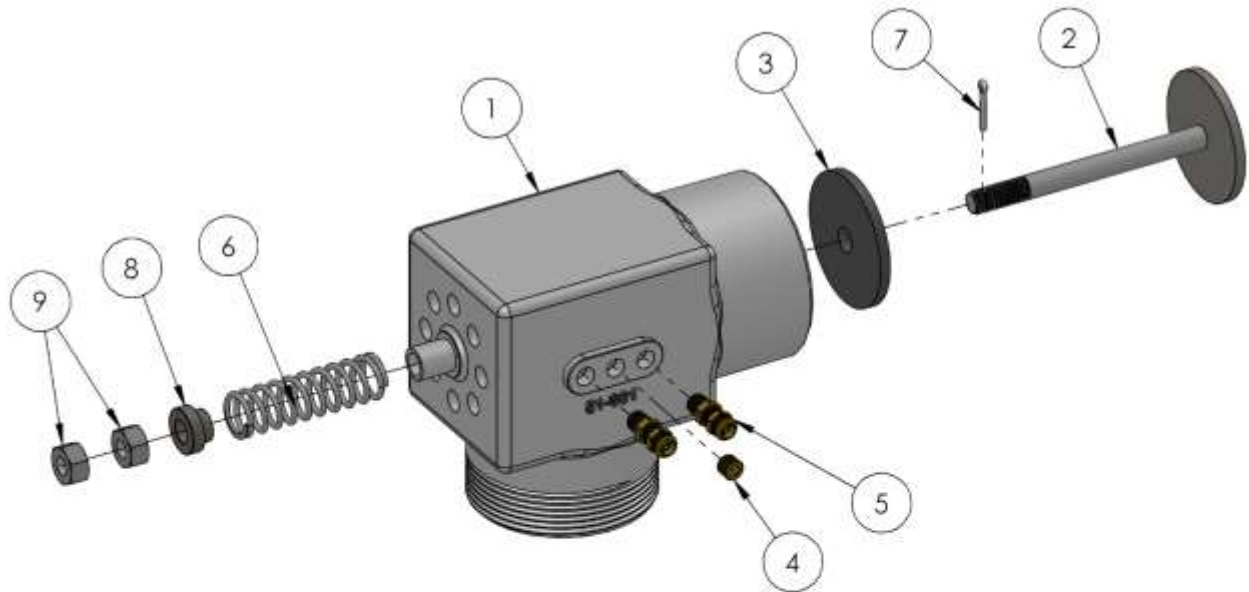

2	9	11-012	NUT, 7/16-14 ZP
1	8	66-501	BUSHING, SMALL SPRING RETAINER
1	7	14-032	PIN, COTTER 7/64 X 3/4 SS
1	6	15-002	SPRING, VAC RELIEF VALVE
2	5	21-028	CONN, 1/8 P X 1/4 POLY
1	4	21-029	PLUG, 1/8 NPT SOCKET HD BRASS
1	3	41-009	DIAPHRAGM, VAC RELIEF VLV 4L, 5M
1	2	61-1138	WELDMENT, VAC RELIEF STEM
1	1	66-001	VACUUM BRAKE, MACHINED 4L
QTY	ITEM	PART NO.	DESCRIPTION

69-184, ASSEMBLY, BELT GUARD BLOWER

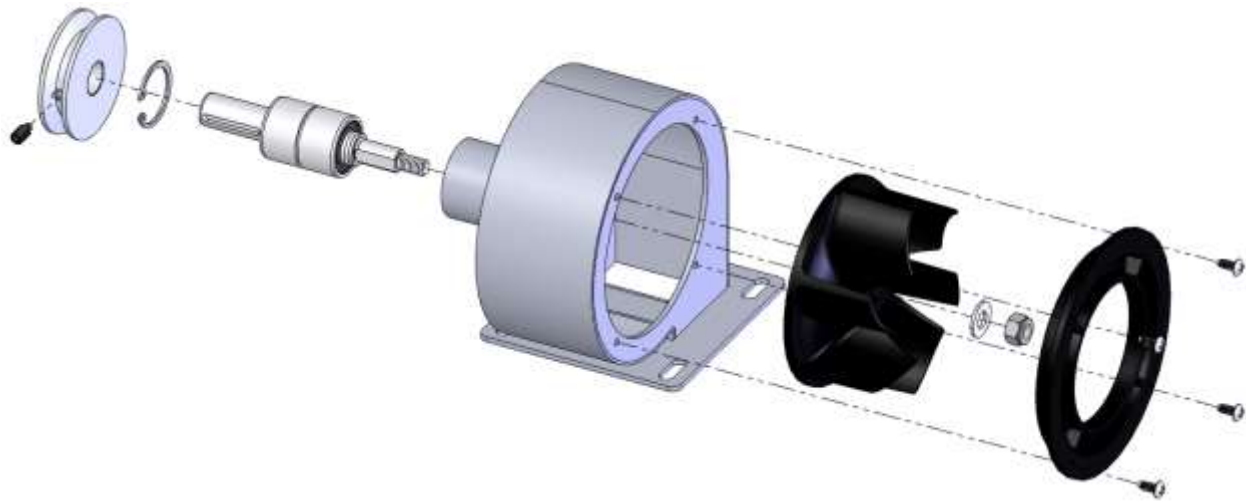

1	10	15-027	SNAP RING, 1.187 INTERNAL
1	9	39-075	BEARING, BELT GUARD BLOWER
1	8	10-219	SCREW, FULL DOG SET 1/4-20 X 1/2 BLK
1	7	11-029	NUT, 5/16-18 NYLOCK
1	6	12-017	WASHER, FLAT 5/16 SAE ZINC
1	5	51-043	COVER, AIR WHEEL
1	4	51-042	AIR WHEEL, MOLDED
4	3	10-146	SCREW, 8-32 X .375 PHP F THREAD CUTTING ZP
1	2	66-215	PULLEY, 3L BELT X 2.340 OD
1	1	61-465	WELDMENT, BLOWER HOUSING
QTY	ITEM	PART NO.	DESCRIPTION

69-403, ASSEMBLY, BIG GULP 3500 RECOVERY TANK

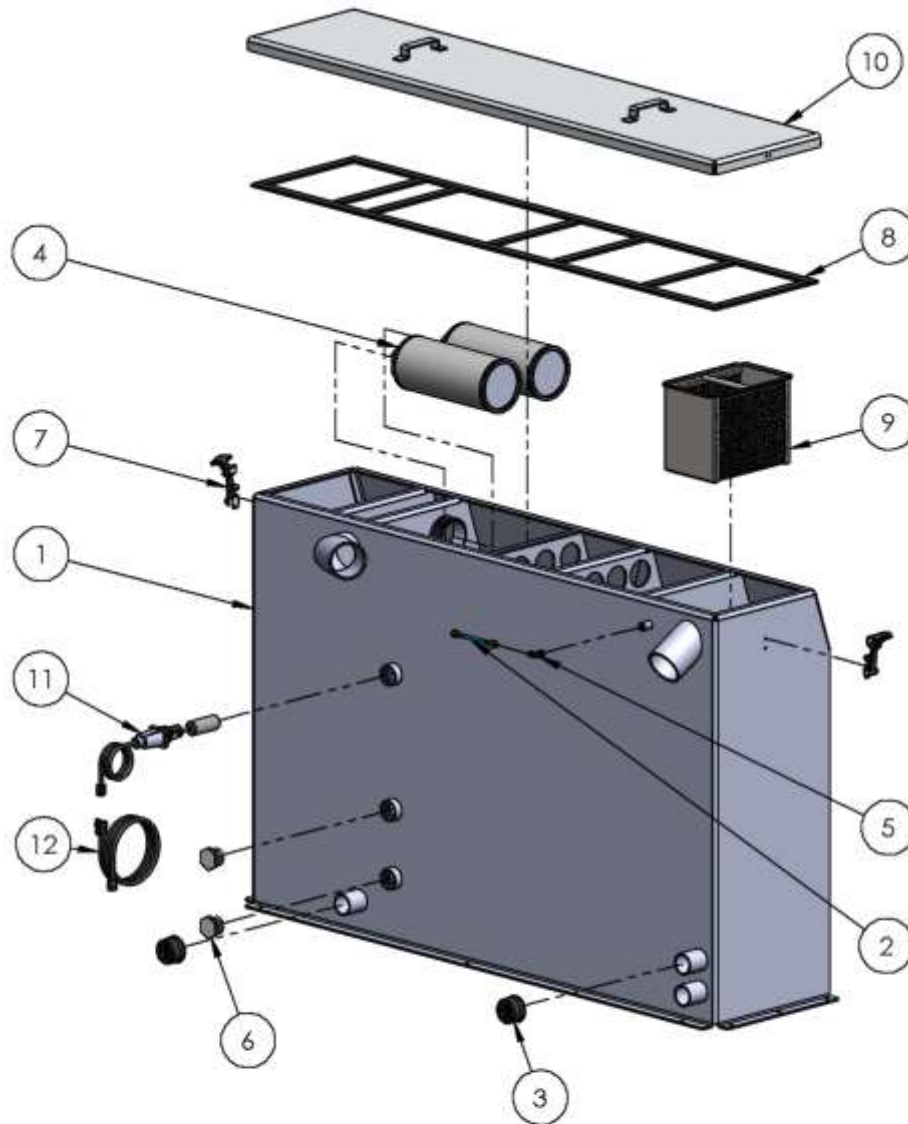

1	12	47-095	HARNES, LEVEL SENSOR EXTENSION
1	11	69-000	FLOAT SWITCH
1	10	61-672	WELDMENT, LID LARGE RECOVERY TANK
1	9	61-002	WELDMENT, STRAINER BASKET
199 IN	8	41-01B	GASKET, SPONGE 1 IN X 45 FT
2	7	40-003	LATCH, PRE-FILTER BOX
2	6	21-097	PLUG, 1-1/4 IN PVC
1	5	21-064	ELL, 1/4 P X 1/4 T BRASS
2	4	20-021	STRAINER, FILTER 3" 100 MESH
2	3	19-009	CAP, 2 IN RUBBER
1	2	18-215-16	HOSE ASSEMBLY, 3-16 ID X 38 OL
1	1	61-795	WELDMENT, 3500 RECOVERY TANK
QTY	ITEM	PART NO.	DESCRIPTION

DECALS



**ELECTRICAL SHOCK
COULD CAUSE SEVERE
BURNS OR INJURY. DO
NOT TOUCH ELECTRICAL
WIRES OR COMPONENTS
WHILE THE ENGINE IS
RUNNING. DISCONNECT
THE BATTERY BEFORE
SERVICING THIS UNIT TO
PREVENT ACCIDENTAL
STARTING.**

44-066 A

44-066, WARNING,
ELECTRICAL SHOCK



**READ THE OPERATOR'S MANUAL
BEFORE INSTALLING OR
STARTING THIS UNIT. FAILURE TO
ADHERE TO INSTRUCTIONS CAN
RESULT IN SEVERE PERSONAL
INJURY OR COULD BE FATAL.
REPLACEMENT
MANUALS CAN BE PURCHASED
FROM:
Sapphire Scientific
2804 Liberator
Prescott, AZ 86301**

44-067 A

44-067, WARNING,
READ MANUAL



**ROTATING MACHINERY
CAN CAUSE INJURY OR
COULD BE FATAL.
KEEP ALL GUARDS
AND SAFETY DEVICES
IN PLACE.**

44-085 A

44-085, WARNING,
ROTATING MACHINERY



44-084, CAUTION, HOT
SURFACE

**ROTATING
MACHINERY.
WATER UNDER
PRESSURE AT HIGH
TEMPERATURE.
IMPROPER
MODIFICATION OF
EQUIPMENT CAN
CAUSE SEVERE
PERSONAL INJURY
OR COULD BE
FATAL.**

44-082 A

44-082, DANGER, ROTATING MACHINERY



**DO NOT MODIFY
UNIT WITHOUT
WRITTEN
PERMISSION
FROM
MANUFACTURER**

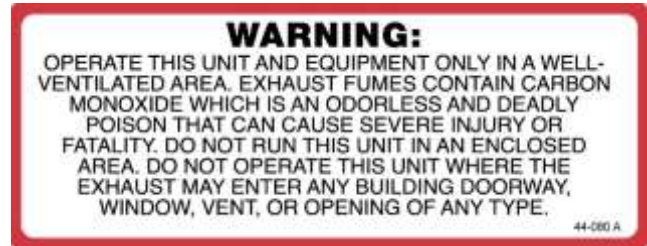

44-080 A

44-080, WARNING, VENTILATED AREA



44-125, DECAL, PRODUCT BIG GULP 3500



44-187, DECAL, CO DANGER



44-277, DECAL MOMENTARY PUMP OVERRIDE

ELECTRICAL DIAGRAM (3500 SHOWING OPTIONAL WASTE PUMP)

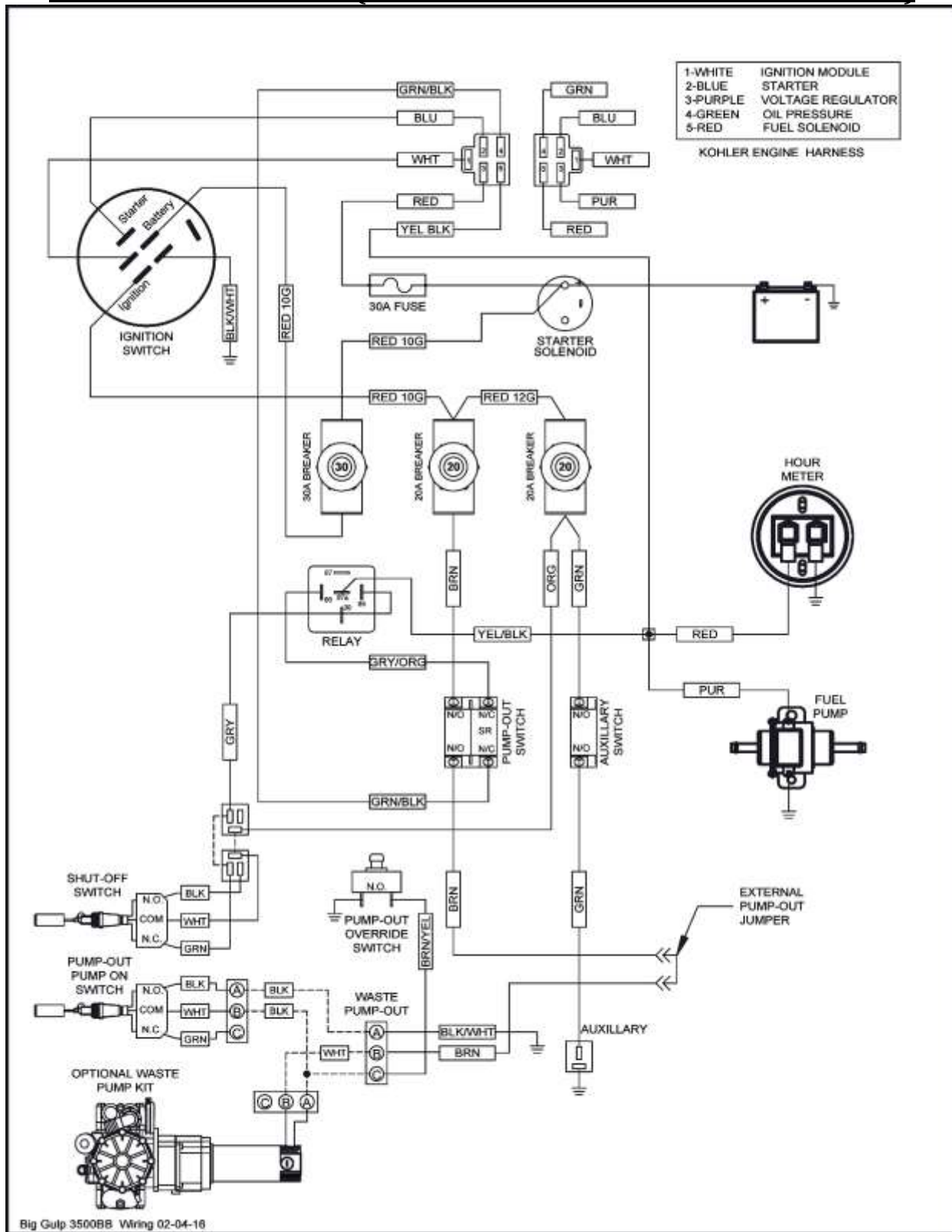

ELECTRICAL DIAGRAM (3501 W/WASTE PUMP INSTALLED)

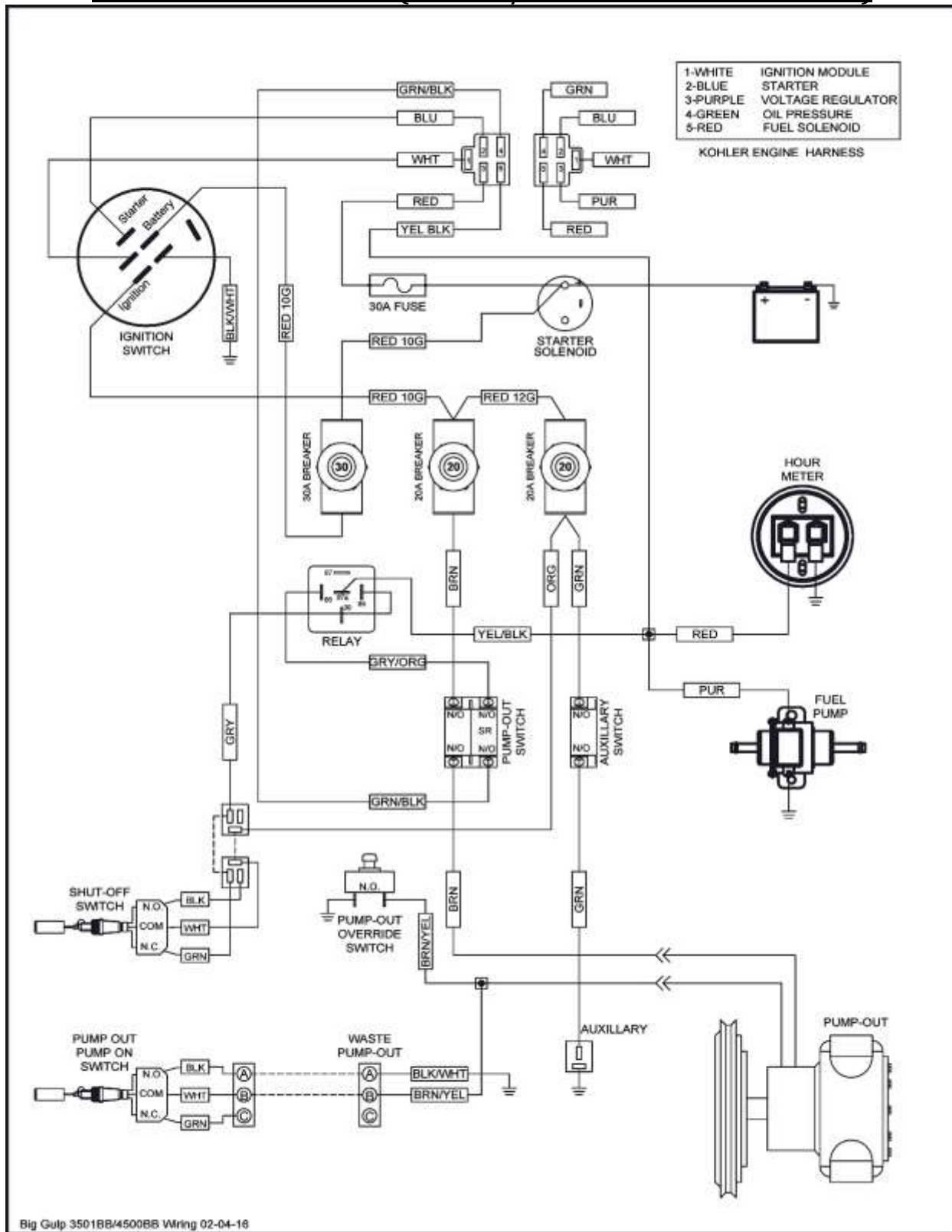

69-388, ASSEMBLY, WASTE PUMP OUT (OPTIONAL COMPONENT)

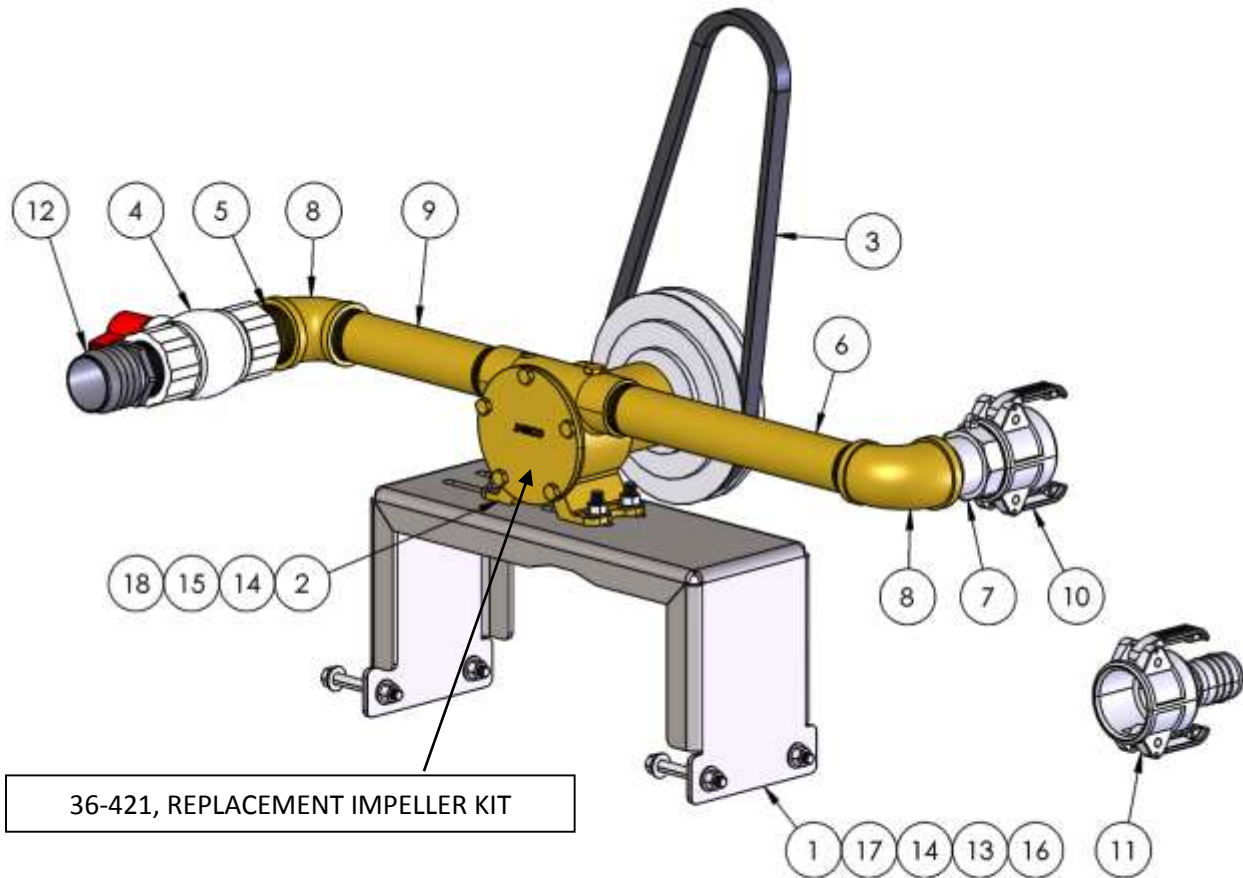

36-421, REPLACEMENT IMPELLER KIT

4	18	10-004	SCREW, MACH 3/8-16 X 1-1/4 HEXHD
4	17	10-030	SCREW, MACH 3/8-16 X 3 HXHD
4	16	11-006	NUT, 3/8-16 ZINC
4	15	11-019	NUT,3/8-16 NYLOK
16	14	12-013	WASHER, FLAT 3/8 SAE
4	13	12-014	LKWSR, 3/8 ZINC
1	12	21-094	FTTG, 1-1/2 P X 2H DRAIN
1	11	21-307	COUPLING,ALUM LL 1 1/2 X 2 1/8X
1	10	21-308	COUPLING,AL CAP 1 1/2 X 2 1/8X
1	9	21-496	NIPPLE, 1-1/4 NPT X B BRASS
2	8	21-339	ELBOW, FEMALE 1.50 NPT REDUCE TO 1.25 NPT BRASS
1	7	21-356	ADAPTER, 1-1/2 NPT X 1-1/2 CAM & GROOVE
1	6	21-386	NIPPLE, 1.25 NPT X 12 BRASS NIPPLE
1	5	21-392	NIPPLE, 1-1/2 NPT CLOSE BRASS
1	4	23-022	VLV, BALL 1-1/2 FP PVC DUMP
1	3	37-086	BELT, BX38 GATES COG V
1	2	46-054	PUMP, JABSCO 1187-0005 12-2A
1	1	60-1328	BRACKET, PUMP MOUNT
QTY	ITEM	PART NO.	DESCRIPTION

69-333, ASSEMBLY, WINTERIZING KIT (OPTIONAL COMPONENT W/WASTE PUMP)

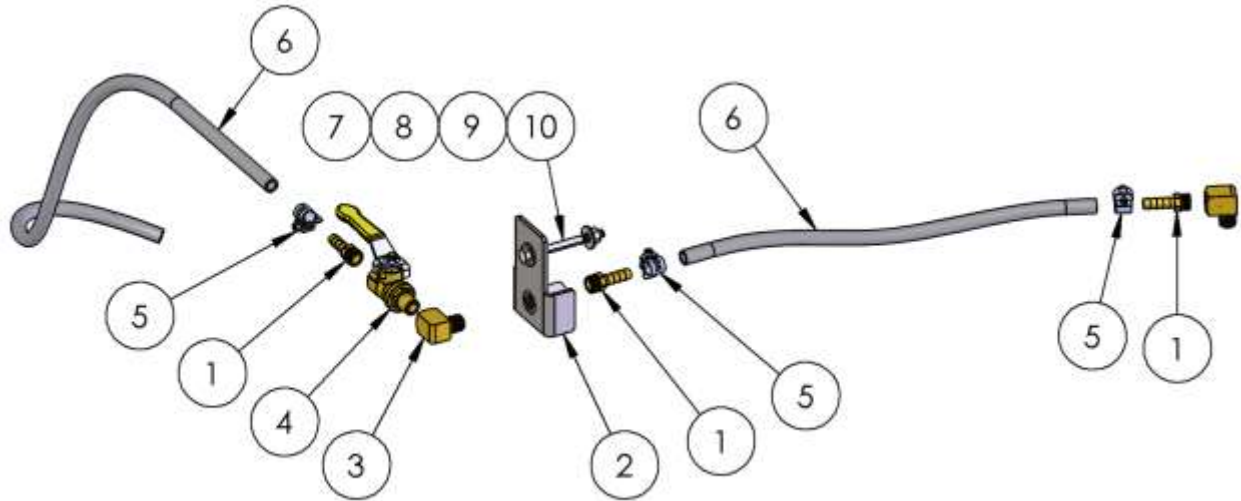

1	10	10-028	SCREW, MACH 1/4-20 X 2-3/4 HXHD
2	9	12-012	WASHER, FLAT 1/4 USS
1	8	12-015	LKWSR, 1/4 ZINC
1	7	11-004	NUT, 1/4-20 ZINC
3.00 FT	6	16-006	HOSE, BRAIDED 5/16 ID 300 FT BULK
3	5	14-007	CLAMP, HOSE #4
1	4	23-071	VALVE, BALL 1/4 NPT F X M
2	3	21-039	FITTING - ELBOW 1/4 IN STREET BRASS
1	2	61-489	WELDMENT, GAS LINE BRACKET
3	1	21-006	FTTG, BRB 1/4 P X 5/16 H BRASS
QTY	ITEM	PART NO.	DESCRIPTION

1992 TO 2002 FORD FUEL LINE INSTALLATION

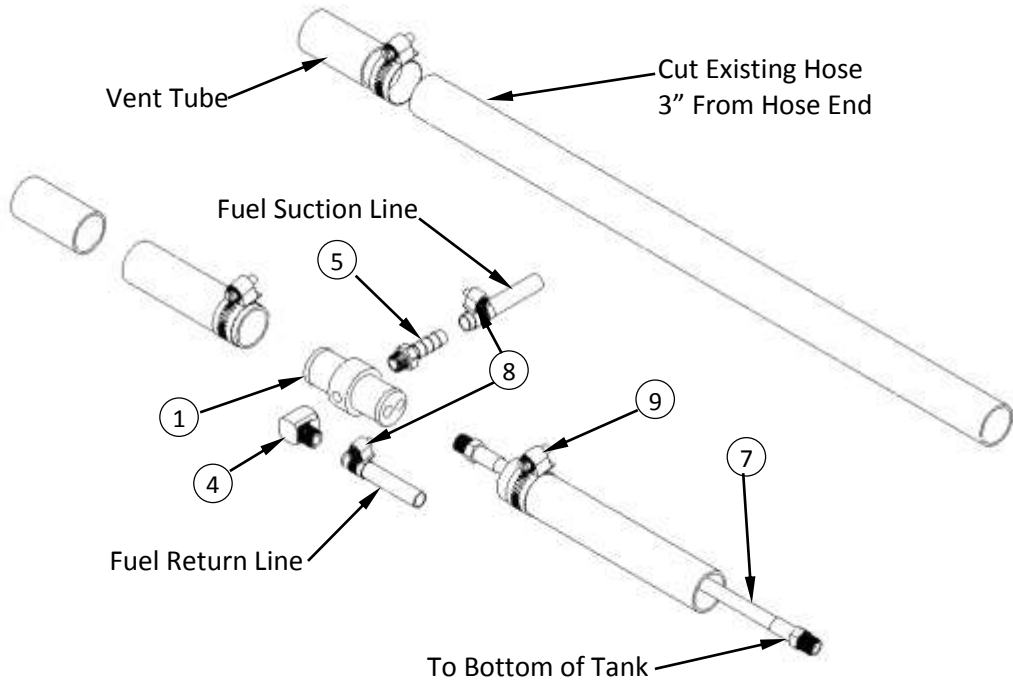

69-005FI KIT, FUEL HOOKUP FORD FI

Item No.	Part Number	Qty	Description
1	66-031	1	ADAPTOR, VENT TUBE(FORD)
2	21-086	2	FTTG, BULKHEAD 1/4 IN BRASS
3	21-039	2	ELL, 1/4 IN LG STREET BRASS
4	21-038	1	ELL, STREET 1/8 IN BRASS
5	21-007	2	FTTG, BRB 1/8P X 5/16 H BR
6	21-006	4	FTTG, BRB 1/4P X 5//16H BR
7	18-028	1	HOSE, 3/16 X 25 (1/8P X 1/8P NO COVER)
8	14-011	6	CLAMP, HOSE FUEL # 6
9	14-000	2	CLAMP, HOSE #12

CHEVY AND GMC FULL SIZE VAN FUEL LINE INSTALLATION

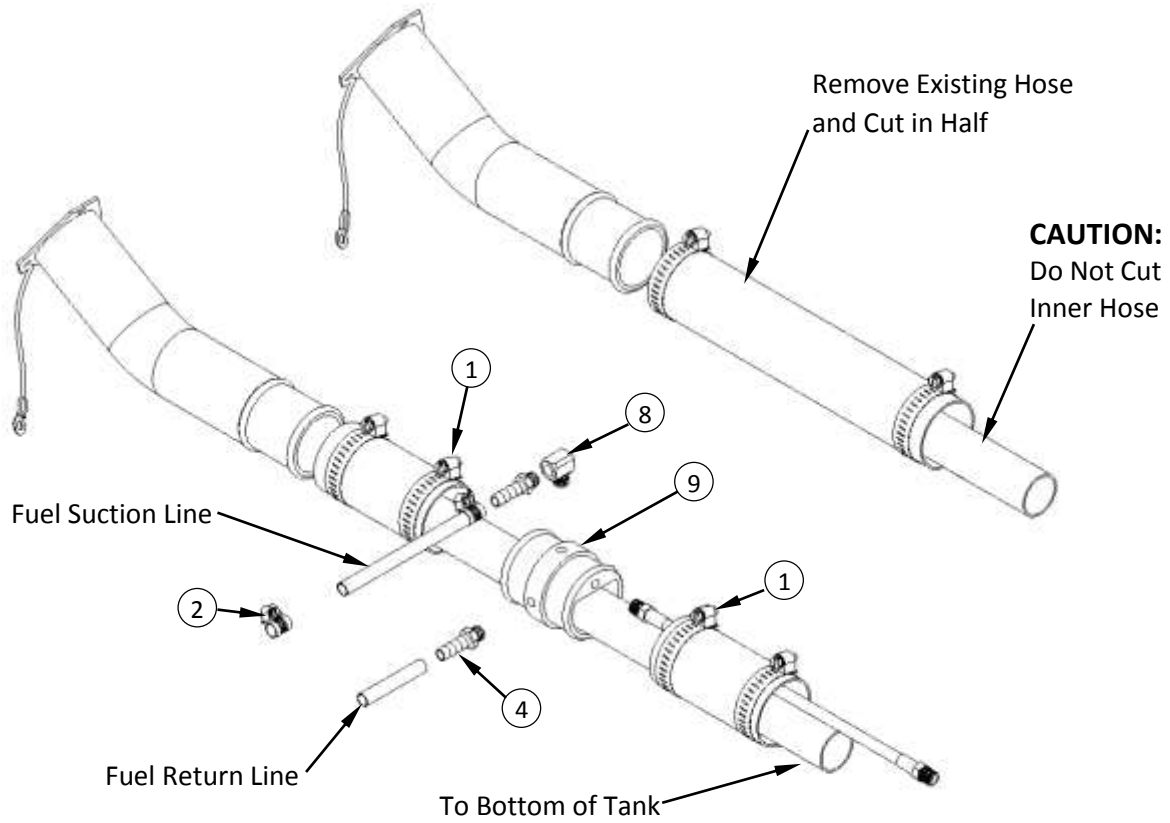

69-003FI KIT, FUEL HOOKUP 97 & 2002 FI

Item No.	Part Number	Qty	Description
1	14-010	2	CLAMP, HOSE # 32
2	14-011	6	CLAMP, HOSE FUEL # 6
3	21-006	4	FTTG, BRB 1/4P X 5//16H BR
4	21-007	2	FTTG, BRB 1/8P X 5/16 H BR
5	21-038	1	ELL, STREET 1/8 IN BRASS
6	21-039	2	ELL, 1/4 IN LG STREET BRASS
7	21-086	2	FTTG, BULKHEAD 1/4 IN BRASS
8	21-116	1	ELL, 1/8 FP X 1/8 FP BRONZE
9	66-030	1	ADAPTOR, FUEL NECK (CHEVY)
10	18-027	2	HOSE, 3/16 X 5 (1/8P X 1/8P NO CVR)

2003 CHEVY AND GMC FULL SIZE VAN FUEL LINE INSTALLATION

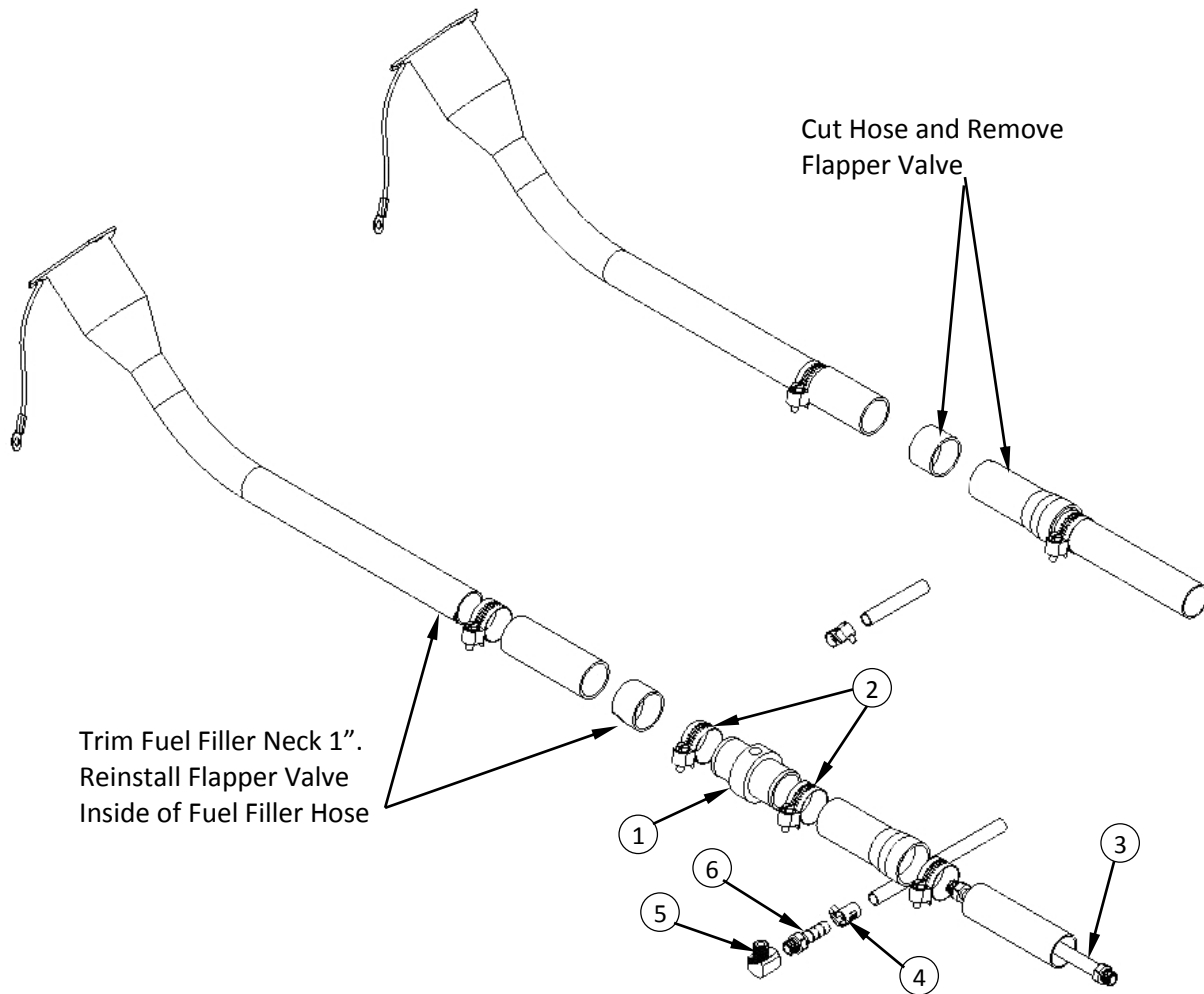

69-018FI KIT, FUEL HOOKUP 2003 CHEVY FI

Item No.	Part Number	Qty	Description
1	66-034	1	ADAPTOR, FUEL FLR CHVY 2003
2	14-006	2	CLAMP, HOSE # 20
3	18-028	1	HOSE, 3/16 X 25 (1/8P X 1/8P NO COVER)
4	14-011	6	CLAMP, HOSE FUEL # 6
5	21-038	1	ELL, STREET 1/8 IN BRASS
6	21-007	2	FTTG, BRB 1/8P X 5/16 H BR
7	21-039	2	ELL, 1/4 IN LG STREET BRASS
8	21-006	4	FTTG, BRB 1/4P X 5//16H BR
9	21-086	2	FTTG, BULKHEAD 1/4 IN BRASS

1997-2002 DODGE FULL SIZE VAN FUEL LINE INSTALLATION

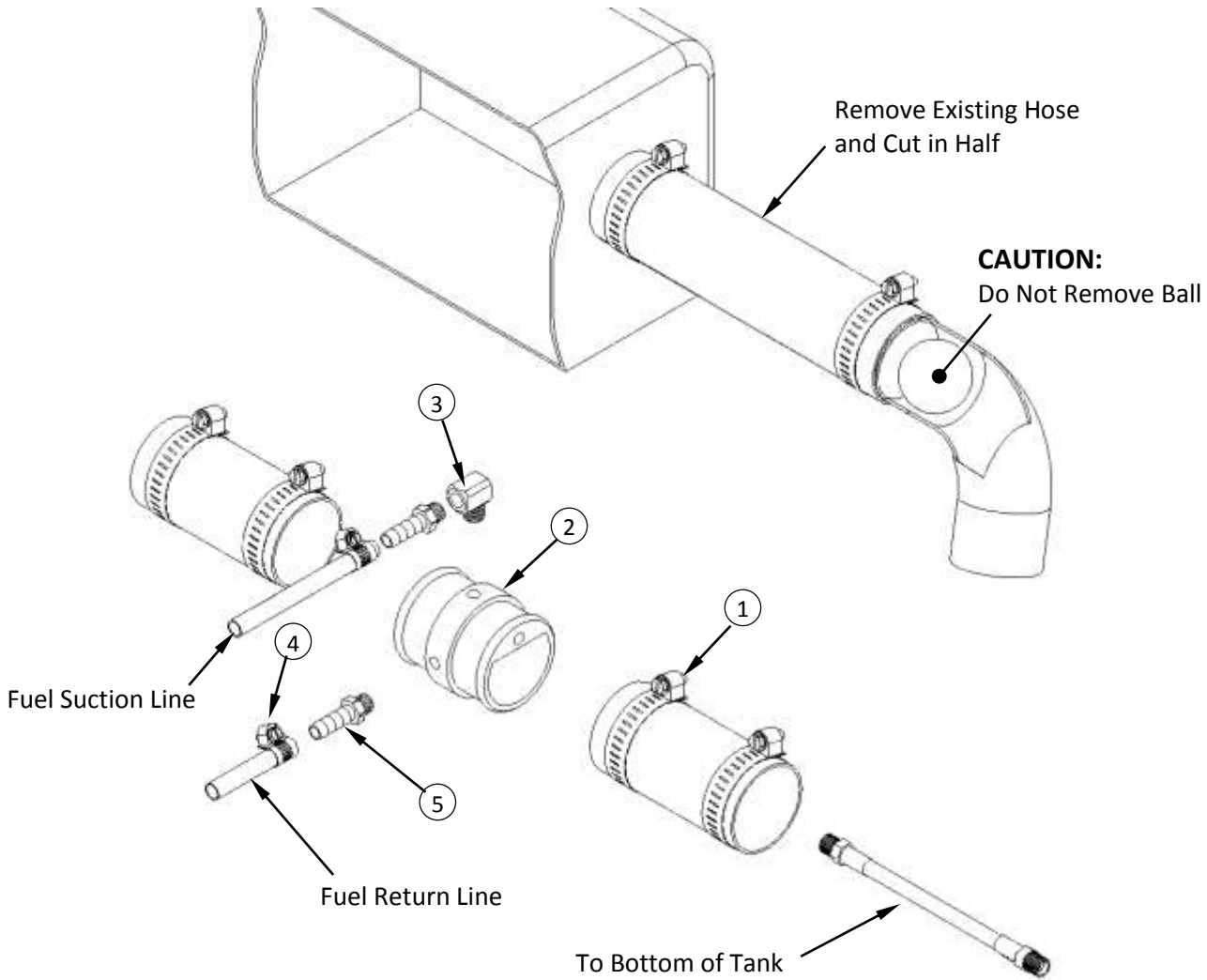

69-004FI KIT, FUEL HOOKUP CHEVY/DODGE FI

Item No.	Part Number	Qty	Description
1	14-010	2	CLAMP, HOSE # 32
2	66-030	1	ADAPTOR, FUEL NECK(CHEVY)
3	21-038	1	ELL, STREET 1/8 IN BRASS
4	14-011	6	CLAMP, HOSE FUEL # 6
5	21-007	2	FTTG, BRB 1/8P X 5/16 H BR
6	18-028	1	HOSE, 3/16 X 25 (1/8P X 1/8P NO COVER)
7	21-086	2	FTTG, BULKHEAD 1/4 IN BRASS
8	21-006	4	FTTG, BRB 1/4P X 5//16H BR
9	21-039	2	ELL, 1/4 IN LG STREET BRASS

Fuel Line Bulkhead Installation (Inside Vehicle)

1. Select an appropriate location on the vehicle floor away from operator or maintenance traffic and away from contact with any accessories or tools while in use or transit. Make sure your hole is within adequate reach of the supplied hose in the finished assembly.
2. Drill a 3/4 inch hole through the vehicle floor at the location chosen for the bulkhead connector.
3. Install the bulkhead connector by inserting the fitting and tightening the nut and lock washer on the opposite side of the vehicle floor.
4. Inside the vehicle, attach the hose barb fitting and connect the fuel line from the console.
5. Drill a 1/2 inch hole nearby the bulkhead fitting for the fuel pump electrical extension harness to pass through.

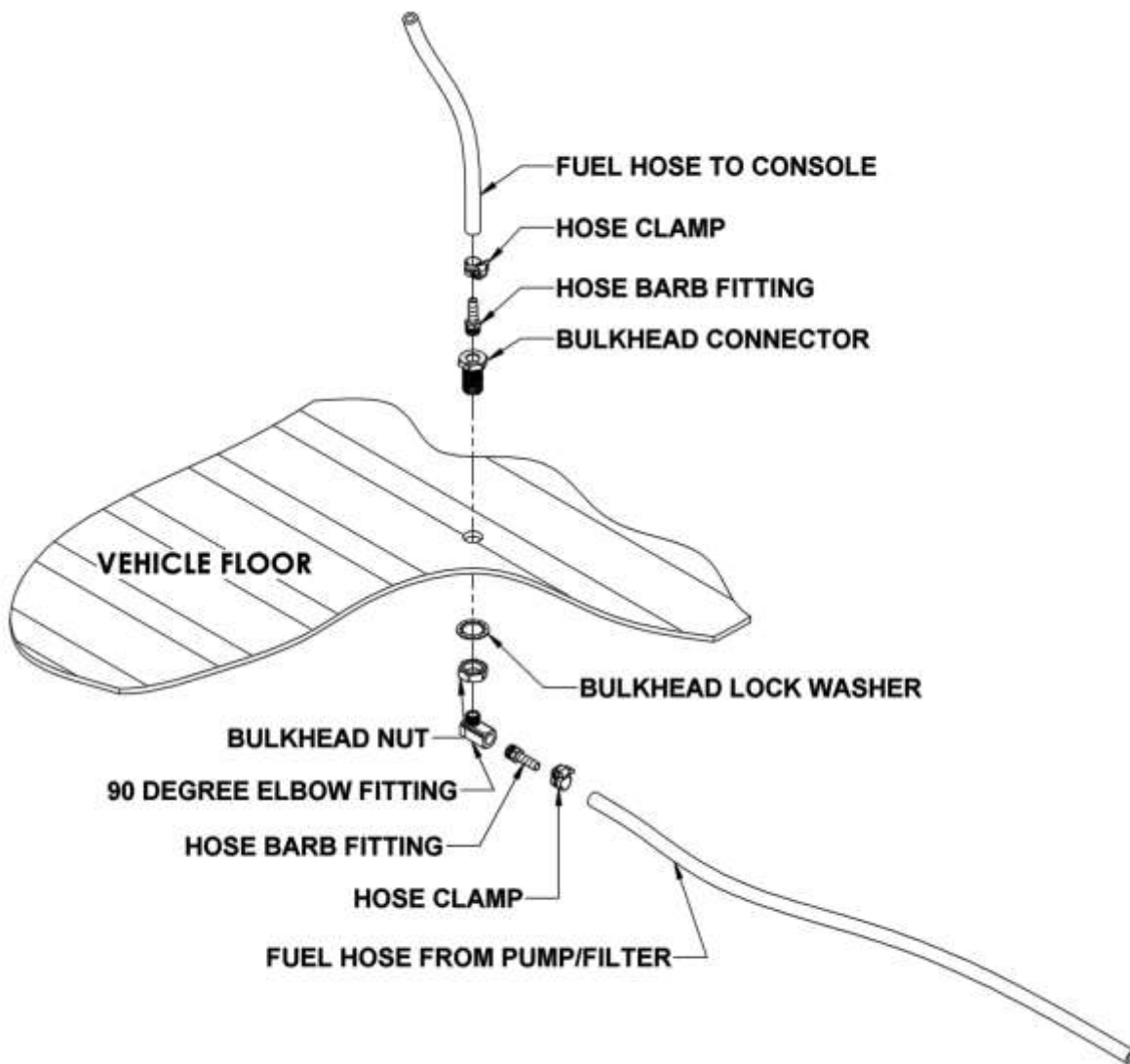

Figure 1. Fuel Line Bulkhead Assembly

Fuel Pump Assembly Installation (Underneath the Vehicle Floor)

1. Locate an appropriate location for the fuel pump assembly housing to mount underneath the vehicle that will not cause damage to the vehicle or compromise the fuel line routing or components.
2. Remove the housing lid from the fuel pump assembly.
3. Use the supplied Tek screws to install the lid of the fuel pump housing to the vehicle.

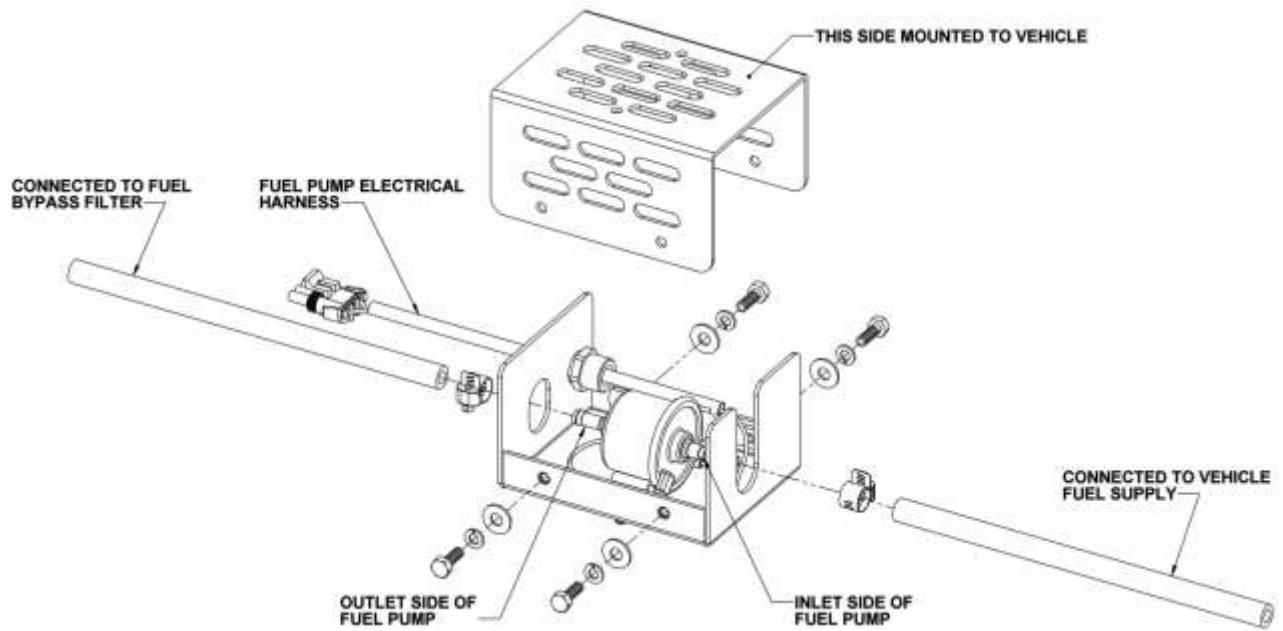

Figure 2. Fuel Pump Assembly Detail

Fuel Supply & Return Line Installation (Underneath the Vehicle Floor)

1. Refer to the transfer flow kit instructions found with the appropriate kit for your vehicle.
2. Connect the fuel line from the transfer flow kit to the inlet side of the fuel pump.
3. Connect the outlet side of the fuel pump to the inlet side of the fuel bypass filter.
4. Connect the return line from the bypass filter return port back to the vehicle fuel supply.

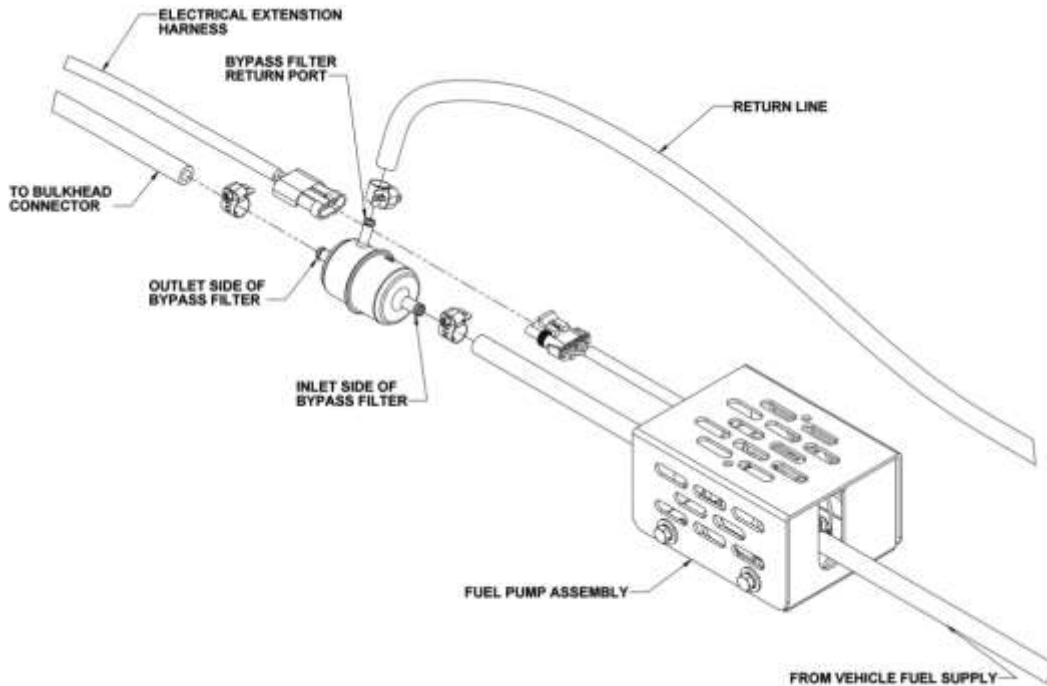

Figure 3. Fuel Pump and Filter Detail

5. Attach the 90 degree elbow and hose barb fittings to the bulkhead connector underneath the vehicle.
6. Connect a segment of hose between the outlet side of the fuel bypass filter to the hose barb fitting.
7. Ensure that all hose clamps are properly tightened.
8. Connect the electrical extension harness to the fuel pump harness, running the other end up through a hole in the floor of the vehicle, connecting to the console harness.

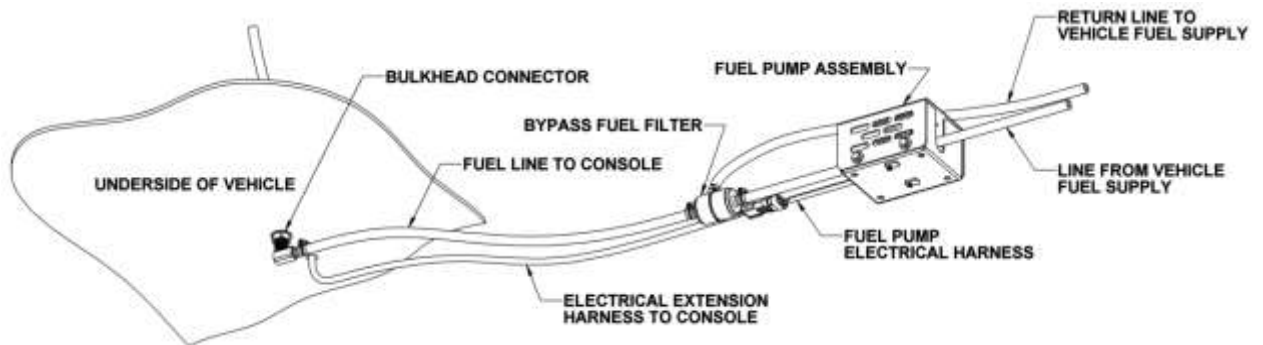

Figure 4. Vehicle Underside Fuel Line Installation